

3

Profile cutterblocks and cutterheads Fraises et porte-outils profil



Chamfering cutterblock and cutterhead	
Fraise et porte-outils à chanfrein	3.3-3.5
V-grooving cutterblock for Alucobond®	
Fraise à chanfreinage pour Alucobond®	3.6
Chamfering and radiated	
Fraise et porte-outils à dresser, biseauter et arrondir.....	3.7-3.9
Rounding cutterhead and cutterblock	
Fraise et porte-outils à arrondir	3.9-3.11
Half round convex radius shaper	
Fraise et porte-outils à rayon 1/2 rond convexe	3.12-3.13
Multiple dowel cutterblock	
Fraise à bâtons multiples	3.14
Universal profile cutterblock	
Porte-outils multi-profil	3.15-3.16
Profile cutterset Multicut 5	
Jeu de fraises profil Multicut 5	3.17-3.18
Universal profile cutterhead “unic”	
Porte-outils multi-profil “unic”	3.19-3.22
Universal profile cutterhead	
Porte-outils à profiler universel	3.23-3.24
Moulding cutterhead	
Porte-outils à profiler	3.25-3.28
Universal cutterhead with profiled knives	
Porte-outils universel à couteaux profilés	3.29-3.38
Profile cutterblock	
Fraise-Profil	3.39-3.45
Handrail profile cutterblock	
Fraise pour main courante	3.39-3.45

Adjustable chamfering cutterhead Porte-outil à chanfreiner ajustable

D	D _{max.}	B	d	Z	n _{min.-max.}	Ref.
140	163	50	30	2	5500-7500	510.103
170	193	50	30/50	2	4500-6000	510.102
	218	80	30/50	3	4500-6000	510.301

Spare parts - Pièces de rechange

nr.	B	Dim.	Ref.
1 Knife - <i>Plaquette</i>		50x12x1,5 80x13x2,2	750.106 750.108
2 Clamping wedge - <i>Cale</i>	50 80		707.121 707.128
3 Screw - <i>Vis</i>		M8x10	705.540
4 Blocking sleeve - <i>Écrou de serrage</i>			709.109
5 Screw - <i>Vis</i>		M8x30	705.341
6 Screw - <i>Vis</i>		M8x50	705.555
7 T Wrench- <i>Clé en T</i>		SW4 SW5	706.104 706.105

MAN HW

510

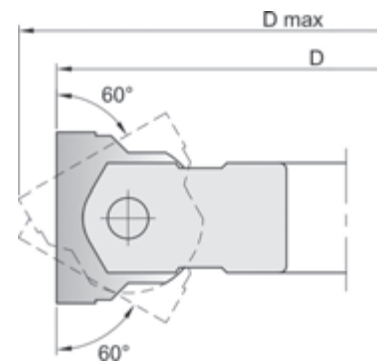
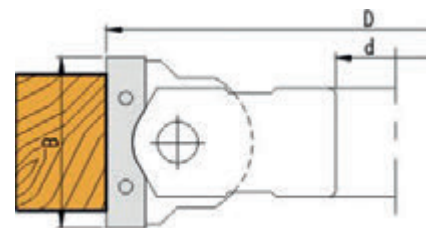

Scale in 2,5° increment
Échelle avec 2,5° espacement

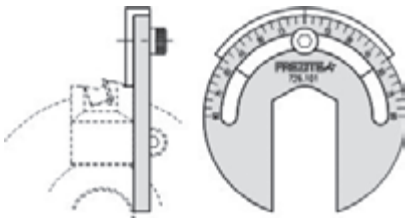

Ref. 726.101
Scale in 1° increment
Échelle avec 1° espacement

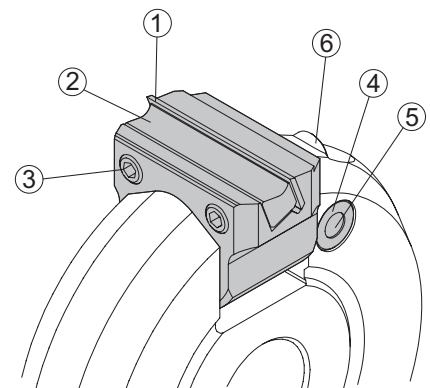

Chamfering cutterhead Porte-outils à chanfrein

D	B	d	Z	n min.-max.	Ref.
175	50	30/50	4	4300-7400	544.201

Spare parts - Pièces de rechange

	Dim.	Ref.
Knife - Plaquette	50x12x1,5	750.106
Clamping wedge - Cale		707.002.48
Screw - Vis	M8x16	705.542
T Wrench - Clé en T	SW4	706.104

MAN HW

544

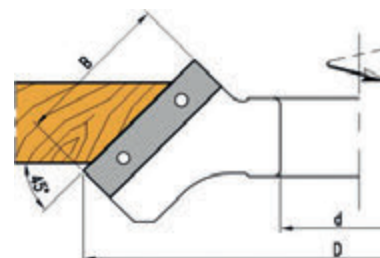

Chamfering cutterblock Fraise à chanfrein

D	B	d	Z	n min.-max.	Ref.INF	Ref.SUP
140	15	30/50	4	5500-9500	407.091	407.092
150	30	30/50	4	5200-8900	407.301	407.302

MAN HW

407

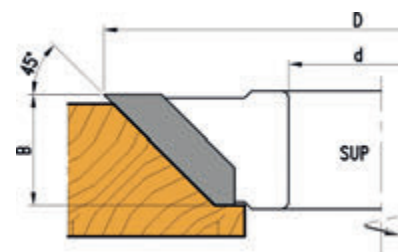

V-grooving cutterhead Porte-outil pour pliage

D	d	Z	n min.-max.	Ref.
140	30/50	2+2	5500-9500	519.201

Spare parts - Pièces de rechange

	Dim.	Ref.
Knife - Plaquette	29,5x12x1,5	753.207
Clamping wedge - Cale		inf. 707.133.30 sup. 707.130.30
Screw - Vis	M8x12	705.541
T Wrench - Clé en T	SW4	706.104

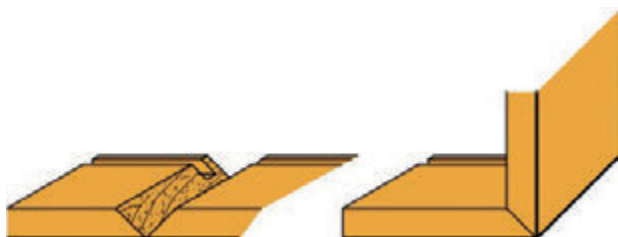

MAN HW

519

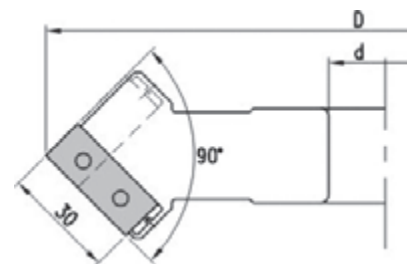

V-grooving cutterblock Fraise pour pliage

D	B	d	Z	n min.-max.	Ref.
140	16	30/50	4	5500-9500	152.301

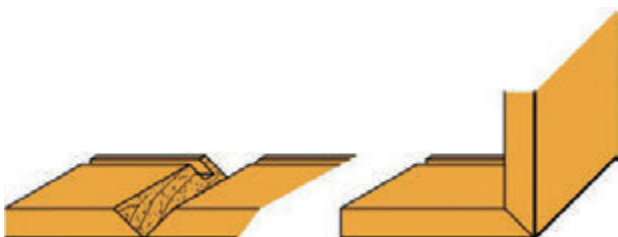

MAN HW

152

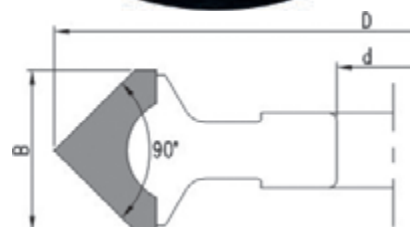

V-grooving cutterblock for Alucobond®
Fraise pour pliage en Alucobond®

	D	B	α	d	Z	$n_{\text{min.-max.}}$	Ref.
new	244	18,5	90°	30	8	3100-7000	315.101
new		18,5	135°	30	8	3100-7000	315.102

MAN HW

315

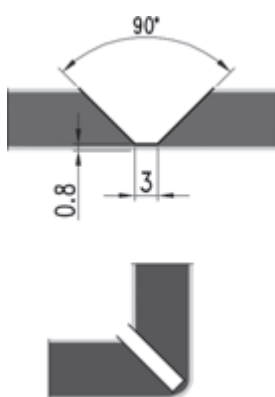
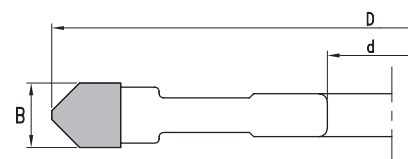

Groove for foldings up to 90°
 Profil en V pour des angles jusqu'à 90°

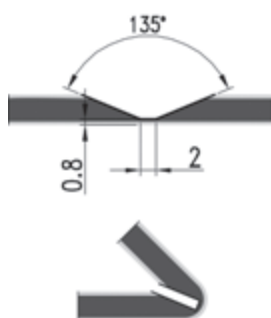

Groove for foldings up to 180°
 Profil en V pour des angles jusqu'à 180°

Chamfering and radiated cutterhead Porte-outil à dresser, biseauter et arrondir

D	B	d	Z	R	n ⁿ min.-max.	Ref.
125	50	40/50	4	4	6200-10600	568.101

MAN HW

568



Cutterheads supplied with rounding blade R=3
Porte-outils fourni avec arrondisseurs R=3

Spare parts - Pièces de rechange

	Dim.	Ref.
Knife - Plaquette	50x12x1,5	750.106
Clamping wedge - Cale		707.002.48
Screw - Vis	M8x13	705.542
Chamfering blade - Chanfreineuse	45°	780.260
Rounding blade - Arrondisseur	R2	780.250
	R3	780.251
Screw - Vis	M5x13,5	705.318
	M5x12	705.523
T Wrench - Clé en T	SW2,5 (M5)	706.102
	SW4 (M8)	706.104

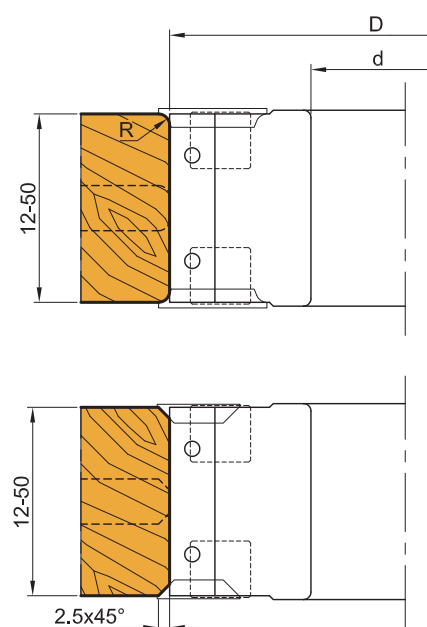

Joining, chamfering and rounding cutterhead
Porte-outils a dresser, biseauter et arrondir

Nr.	D	B	d	Z	R	Ref.
1	100	30	30	2		524.101
1		50	30	2		524.102
1	125	30	40/50	3		524.111
1		50	40/50	3		524.112
2	113	16	30	2	2-6/45°	524.211 ○
2	137	16	40/50	3	2-6/45°	524.212 ○
2	146	25	40/50	3	8-10/45°	524.213 ○

○ Cutterhead supplied without knives - [Porte-outils livré sans plaquettes](#)

Spare parts - Pièces de rechange

	Dim.	Ref.
Knife - Plaquette	30x12x1,5	750.104
	50x12x1,5	750.106
	R2 16x17,5x2	765.101
	R3 16x17,5x2	765.102
	R4 16x17,5x2	765.103
	R5 16x17,5x2	765.104
	R6 16x17,5x2	765.105
	R8 25x25x2	765.107
	R10 25x25x2	765.109
	7x45° 16x17,5x2	765.501
	10x45° 25x25x2	765.502
Clamping wedge - Cale	B30	707.001.28
	B50	707.001.48
	R2-6 / 45°	707.155
	R8-10 / 45°	707.280
Screw - Vis	R2-6 / 45° M6x10	705.532
	R8-10 / 45° M8x12	705.541
T Wrench - Clé en T	SW3 (M6)	706.103
	SW4 (M8)	706.104

MEC HW

524



Cutter diameter Diamètre de coupe	n max
100-113	11.800
125-137	9.100
125-146	9.100

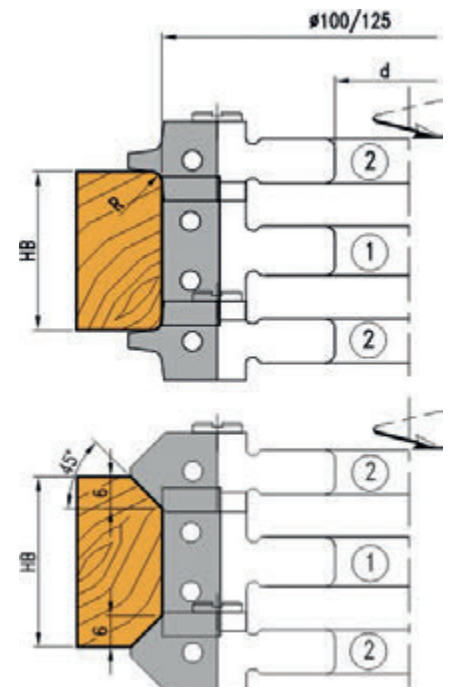

Cutterhead supplied without spacer set.
 Porte-outils livré sans jeu de bagues.

Nr.1 B=30mm

	HB min-max	2x ¹
R2 - 6/45°	14-33	703.009
R8 - 10/45°	21-44	703.010z

Nr.2 B=50mm

	HB min-max	2x ¹
R2 - 6/45°	18-53	703.015
R8 - 10/45°	25-64	703.012

¹ Spacer set

¹ Jeu de bagues

Chamfering and radiated cutterset Jeu de fraises a dresser, biseauter et arrondir

Nr.	D	B	d	Z	R	n _{max.}	Ref.
1	140	60	30/50	3		8500	382.201
2	153	18	30/50	3	5	8500	382.404
3	153	18	30/50	3	5	8500	382.414
1+2+3							382.104

Spacers set - Jeu de bagues

B	Ref.
22	703.015

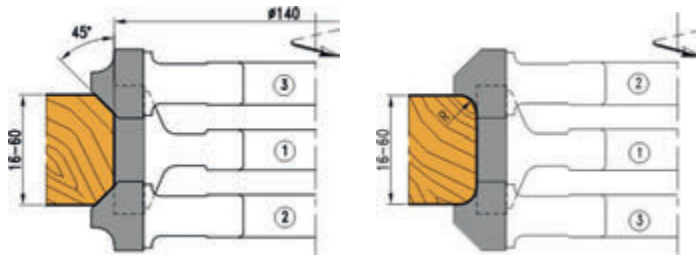

MEC HW

382



3

Rounding cutterhead Porte-outils a arrondir

D	B	d	Z	R	n _{min.-max.}	Ref.
125,5	20	30/50	3	5/7	6100-10500	526.201 ○
132,5	20	30/50	3	8/10	5800-10000	526.202 ○
141	25	30/50	3	12/15	5400-9400	526.203 ○

○ Cutterhead supplied without knives - Porte-outils livré sans plaquettes

Spare parts - Pièces de rechange

	R	Dim.	Ref.
Knife - Plaquette	5	20x20x2	775.201
	7	20x20x2	775.202
	8	20x25x2	775.203
	10	20x25x2	775.204
	12	25x30x2	775.205
	15	25x30x2	775.206
Clamping wedge - Cale	5/7		707.180
	8/10		707.181
	12/15		707.182
Screw - Vis		M8x16	705.542
T Wrench - Clé en T		SW4	706.104

MAN HW

526

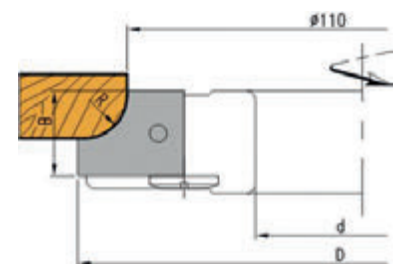
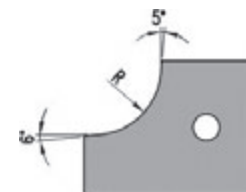

Quarter round concave radius shaper cutterblock
Fraise à rayon 1/4 de rond concave

D	B	d	Z	R	n _{min.-max.}	Ref.INF	Ref.SUP
140	12	30/50	4	5	5500-9500	370.101	370.301
	14	30/50	4	7	5500-9500	370.102	370.302
	15	30/50	4	8	5500-9500	370.103	370.303
	17	30/50	4	10	5500-9500	370.104	370.304
	19	30/50	4	12	5500-9500	370.105	370.305
	22	30/50	4	15	5500-9500	370.106	370.306
	27	30/50	4	20	5500-9500	370.107	370.307
150	33	30/50	4	25	5200-8900	370.108	370.308
160	40	30/50	4	30	4800-8300	370.109	370.309
180	50	30/50	4	40	4300-7400	370.110	370.310

MAN HW

370

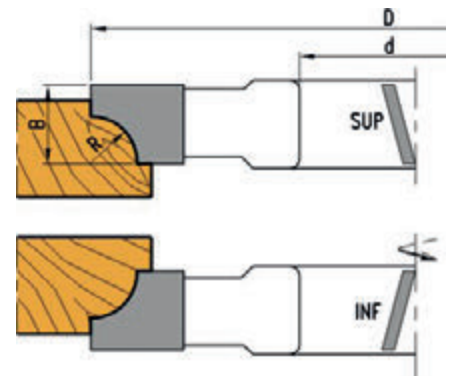

D	B	d	Z	R	n _{min.-max.}	Ref.INF	Ref.SUP
140	12	30/50	4	5	5500-9500	370.501 • 370.701 •	
	14	30/50	4	7	5500-9500	370.502 • 370.702 •	
	15	30/50	4	8	5500-9500	370.503 • 370.703 •	
	17	30/50	4	10	5500-9500	370.504 • 370.704 •	
	19	30/50	4	12	5500-9500	370.505 • 370.705 •	
	22	30/50	4	15	5500-9500	370.506 • 370.706 •	
	27	30/50	4	20	5500-9500	370.507 • 370.707 •	
150	33	30/50	4	25	5200-8900	370.508 • 370.708 •	
160	40	30/50	4	30	4800-8300	370.509 • 370.709 •	
180	50	30/50	4	40	4300-7400	370.510 • 370.710 •	

• Under request - Sur demande

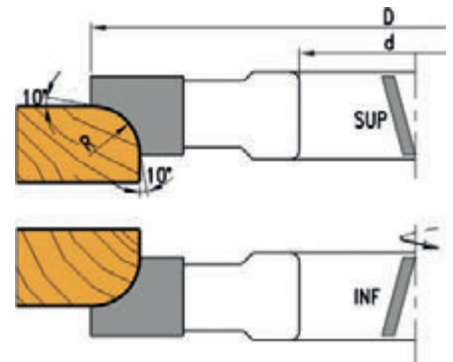

Half round concave radius shaper cutterhead Porte-outils à rayon 1/2 rond concave

D	B	d	Z	R	n min.-max.	Ref.
140	20	30/50	3	4; 5; 6	500-9500	591.101 ◦
	30	30/50	3	8; 10	500-9500	591.102 ◦

◦ Cutterhead supplied without knives - [Porte-outils livré sans plaquettes](#)

Spare parts - Pièces de rechange

	R	Dim.	Ref.
Knife - Plaquette	4	20x20x2	785.761
	5	20x20x2	785.762
	6	20x20x2	785.763
	8	30x25x2	785.764
	10	30x25x2	785.765
Clamping wedge - Cale	4/5/6		707.002.18
	8/10		707.812
Screw - Vis		M8x16	705.542
T Wrench - Clé en T		SW4	706.104

MAN HW

591

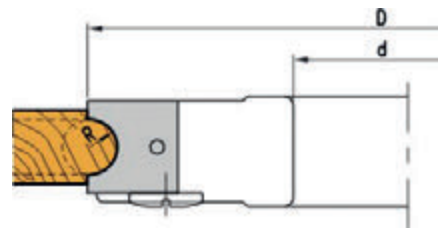

3

Half round concave radius shaper cutterblock Fraise à rayon 1/2 rond concave

D	B	d	Z	R	n min.-max.	Ref.
140	26	30/50	4	6	5500-9500	213.104
	28	30/50	4	7,5	5500-9500	213.110
	30	30/50	4	10	5500-9500	213.105
	40	30/50	4	12,5	5500-9500	213.106
	45	30/50	4	15	5500-9500	213.107
	50	30/50	4	17,5	5500-9500	213.108
	55	30/50	4	20	5500-9500	213.109

MAN HW

213

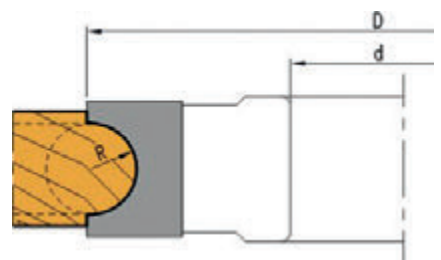

Half round convex radius shaper cutterblock
Fraise à rayon 1/2 rond convexe

D	B	d	Z	R	n min.-max.	Ref.
140	5	30/50	4	2,5	5500-9500	350.101
	6	30/50	4	3	5500-9500	350.099
	8	30/50	4	4	5500-9500	350.100
	10	30/50	4	5	5500-9500	350.102
	12	30/50	4	6	5500-9500	350.104
	15	30/50	4	7,5	5500-9500	350.105
	20	30/50	4	10	5500-9500	350.107
	40	30/50	4	20	5500-9500	350.113

MAN HW

350

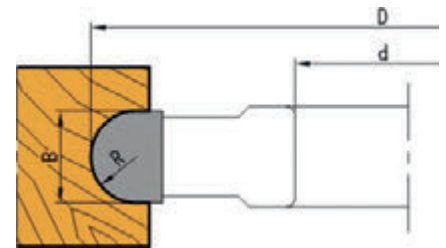

Quarter round convex radius shaper cutterblock
Fraise à rayon 1/4 de rond convexe

D	B	d	Z	R	n min.-max.	Ref.
140	10	30/50	4	5	5500-9500	360.101
	15	30/50	4	10	5500-9500	360.103
	20	30/50	4	15	5500-9500	360.105
	25	30/50	4	20	5500-9500	360.106

MAN HW

360

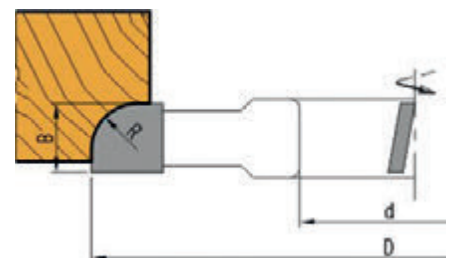

Quarter round concave-convex radius shaper cutterhead
Porte-outils à rayon 1/4 de rond concave-convexe

D	B	d	Z	R	n _{min.-max.}	Ref.
140	20	30/50	3	5, 6, 7	5500-9500	592.101 ○
	25	30/50	3	8,10	5500-9500	592.102 ○
new	35	30/50	3	12,15	5500-9500	592.103 ○

○ Cutterhead supplied without knives - [Porte-outils livré sans plaquettes](#)

Spare parts - Pièces de rechange

	R	Dim.	Ref.
Knife - Plaquette	5	20x20x2	785.766
	6	20x20x2	785.767
	7	20x20x2	785.772
	8	25x25x2	785.773
	10	25x25x2	785.769
	12	35x30x2	785.776
Clamping wedge - Cale	15	35x30x2	785.777
	5,6,7		707.002.18
	8,10		707.811
Screw - Vis	12,15		707.813
	5,6,7	M8x16	705.542
T Wrench - Clé en T	8,10,12,15	M10x20	705.552
		SW4 (M8)	706.104
		SW5 (M10)	706.105

MAN HW

592

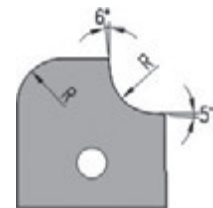
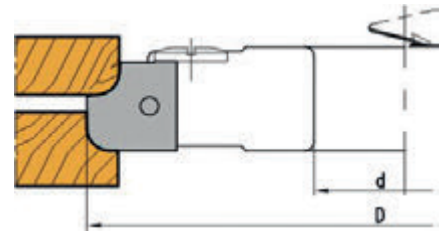

Multiple dowel cutterblock Fraise à bâtons multiples

D	d	n max.
120-130	30/50	10200
131-140	30/50	9500
141-150	30/50	8900
151-160	30/50	8300

• Under request - [Sur demande](#)

MEC HS
HW

214/5



According to DIN 68150.
Selon DIN 68150.

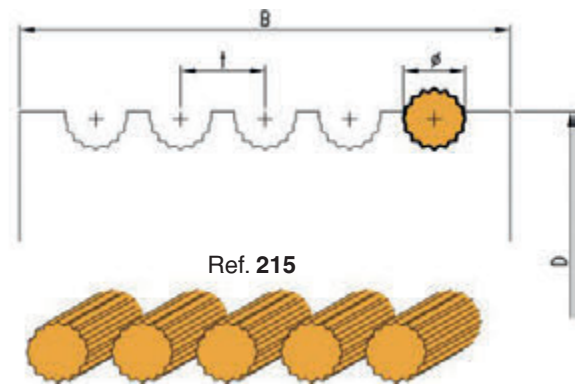
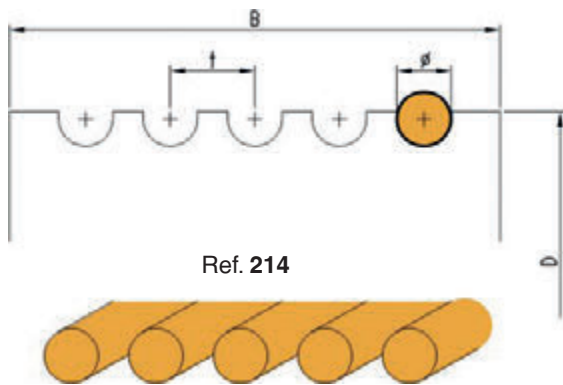

HS

	Ø	6	8	10	12	14	15	16	18	20	25
	t	7	9	11	13,5	15,5	16,5	17,5	19,5	22	27
		B= Cutter width - Largeur de coupe									
Nr. of dowels Nr. de bâtons	2	23	27	31	35,5	39,5	41,5	43,5	47,5	56	66
	3	30	36	42	49	55	58	61	67	78	93
	4	37	45	53	62,5	70,5	74,5	78,5	86,5	100	120
	5	44	54	64	76	86	91	96	106	122	-
	6	51	63	75	89,5	101,5	107,5	113,5	125,5	-	-
	7	58	72	86	103	117	124	-	-	-	-
	8	65	81	97	116,5	-	-	-	-	-	-

t (HW) = t (HS) + 1mm

In order to ensure perfect machining of dowels, the application of a guide rail is recommended.
Pour assurer des bâtons parfaits, nous recommandons l'utilisation d'un sabot de guidage.

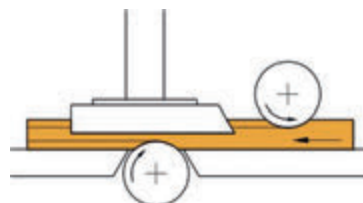

Universal profile cutterhead
Porte-outils multi-profil

D	B	d	Z	n min.-max.	Ref.
140	50	30/50	2	5500-9500	593.101

MAN HW

593



Spare parts - Pièces de rechange

Dim.	Ref.
50x30x2	785.771
Clamping wedge - Cale	707.952
Screw - Vis	M8x16
T Wrench - Clé en T	SW4



Universal profile cutterblock
Fraise multi-profil

Nr.	D	B	d	Z	n min.-max.	Ref.
1	120	40	30	2	6400-11100	211.110
1	140	40	50	3	5500-9500	211.301
2		50	50	3	5500-9500	211.302

MAN HW

211

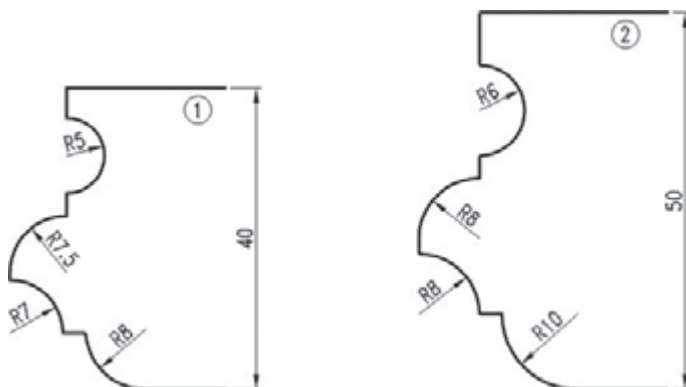

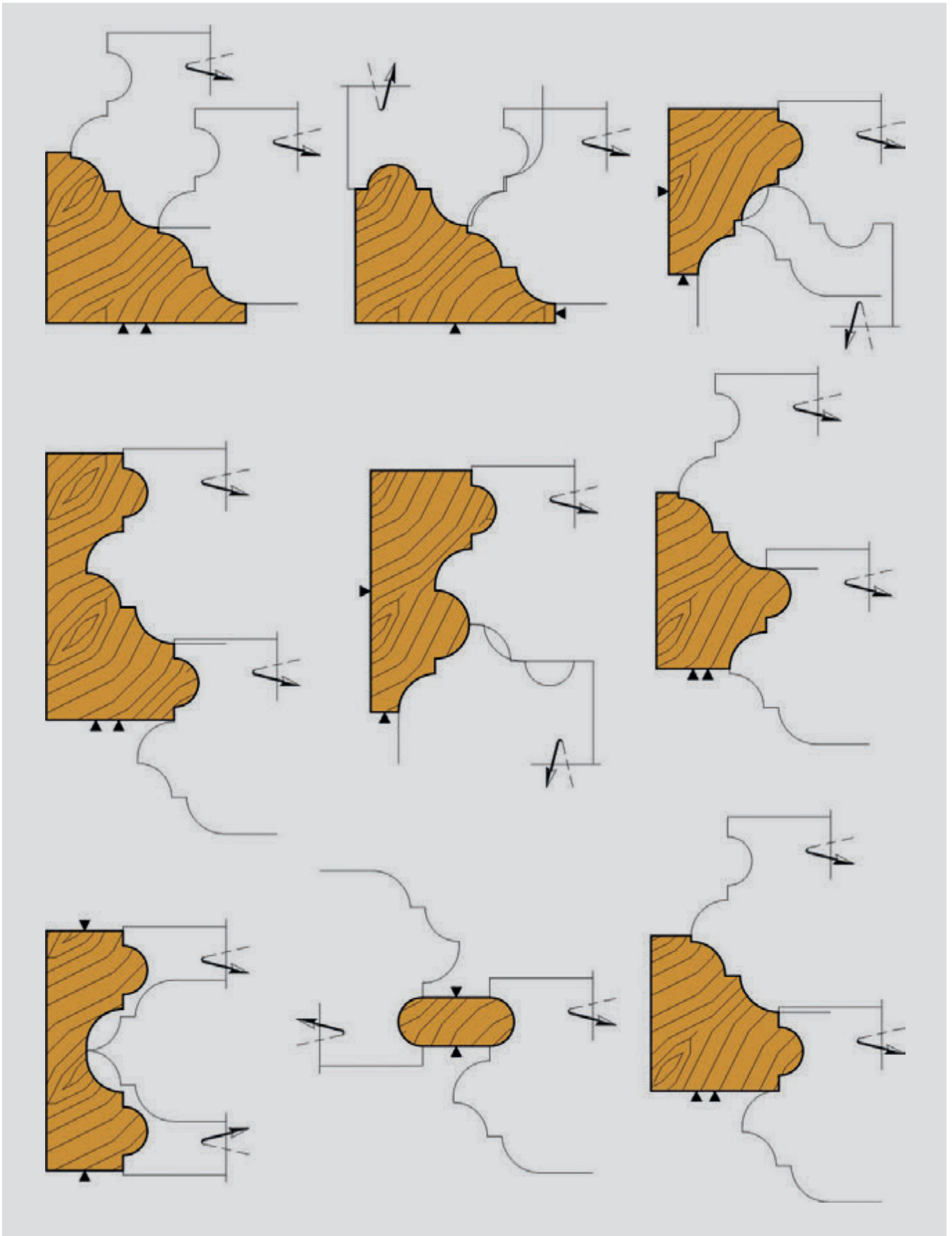

D	d	Z	n _{min.-max.}	Ref.
120	30	2	6400-11100	480.382
140	50	2	5500-9500	481.382

MAN HW

480/1



Set composed by 5 cutters.
Jeu composé par 5 fraises.

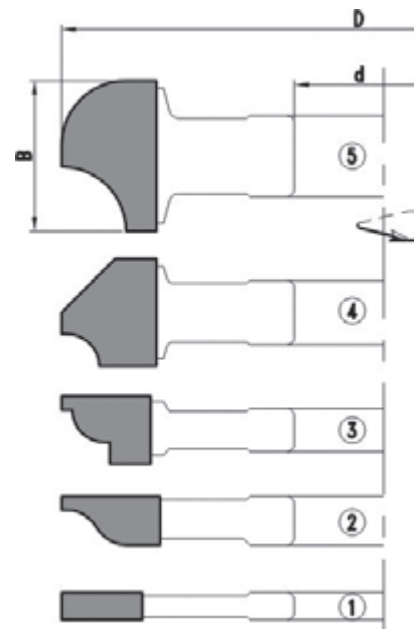
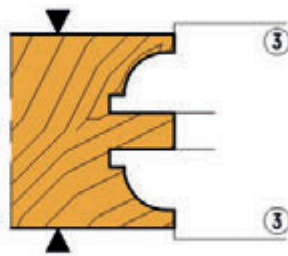
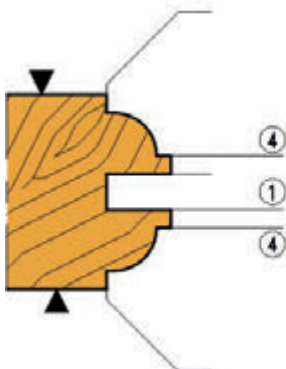
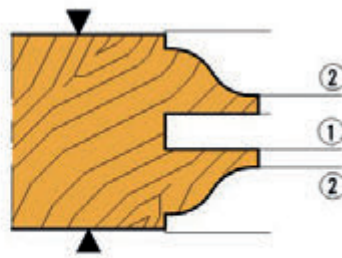
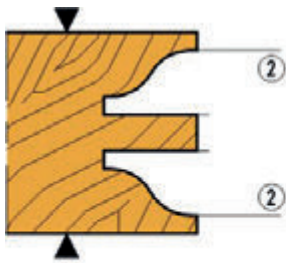

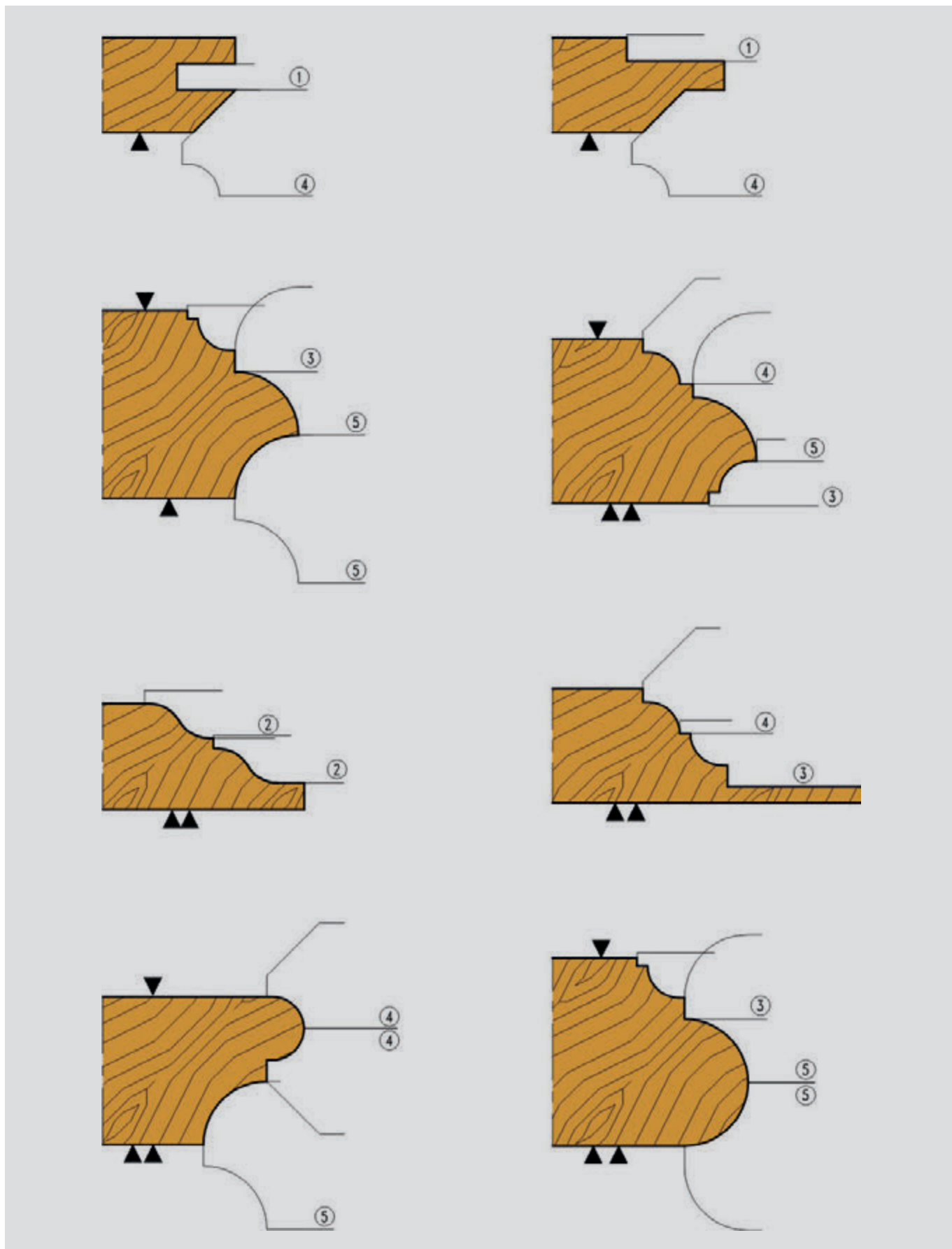

Universal profile cutterhead
Porte-outils multi-profil

unic-a

D	B	d	Z	n _{max.}	Ref.
140	20	50	3	9500	567.101 ○

MEC HW

567



Spare parts - Pièces de rechange

		Dim.	Ref.
Knife - Plaquette	P1	20x25x2	785.631
	P2	20x25x2	785.632
	P3	20x25x2	785.633
	P4	20x25x2	785.634
	P5	20x25x2	785.635
	P6	20x25x2	785.636
	P7	20x25x2	785.637
	P8	20x25x2	785.638
	P9	20x25x2	785.639
	P10	20x25x2	785.640
	P11	20x25x2	785.641
	P12	20x25x2	785.642
	P13	20x25x2	785.643
	P14	20x25x2	785.644
	P15	20x25x2	785.645
	P16	20x25x2	785.646
Clamping wedge - Cale			707.090
Screw - Vis		M8x16	705.542
T Wrench - Clé en T	R3	SW4	706.104

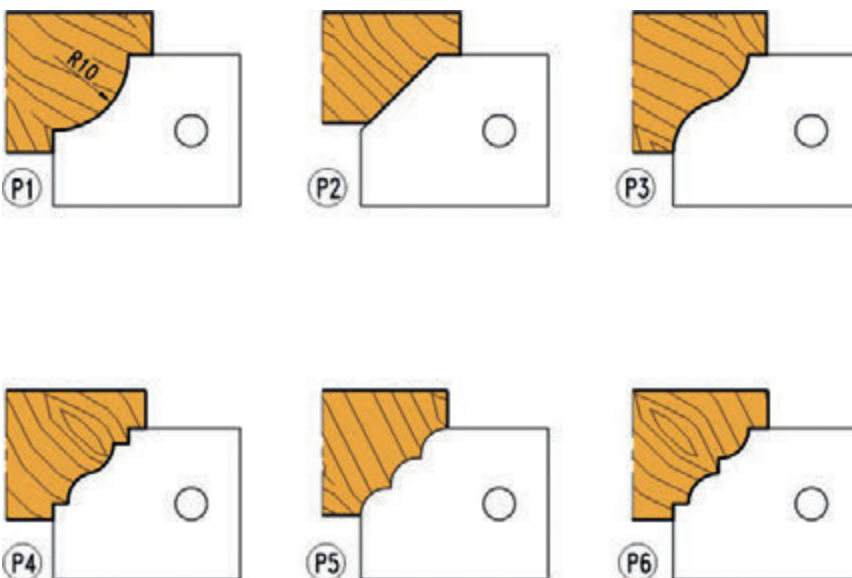

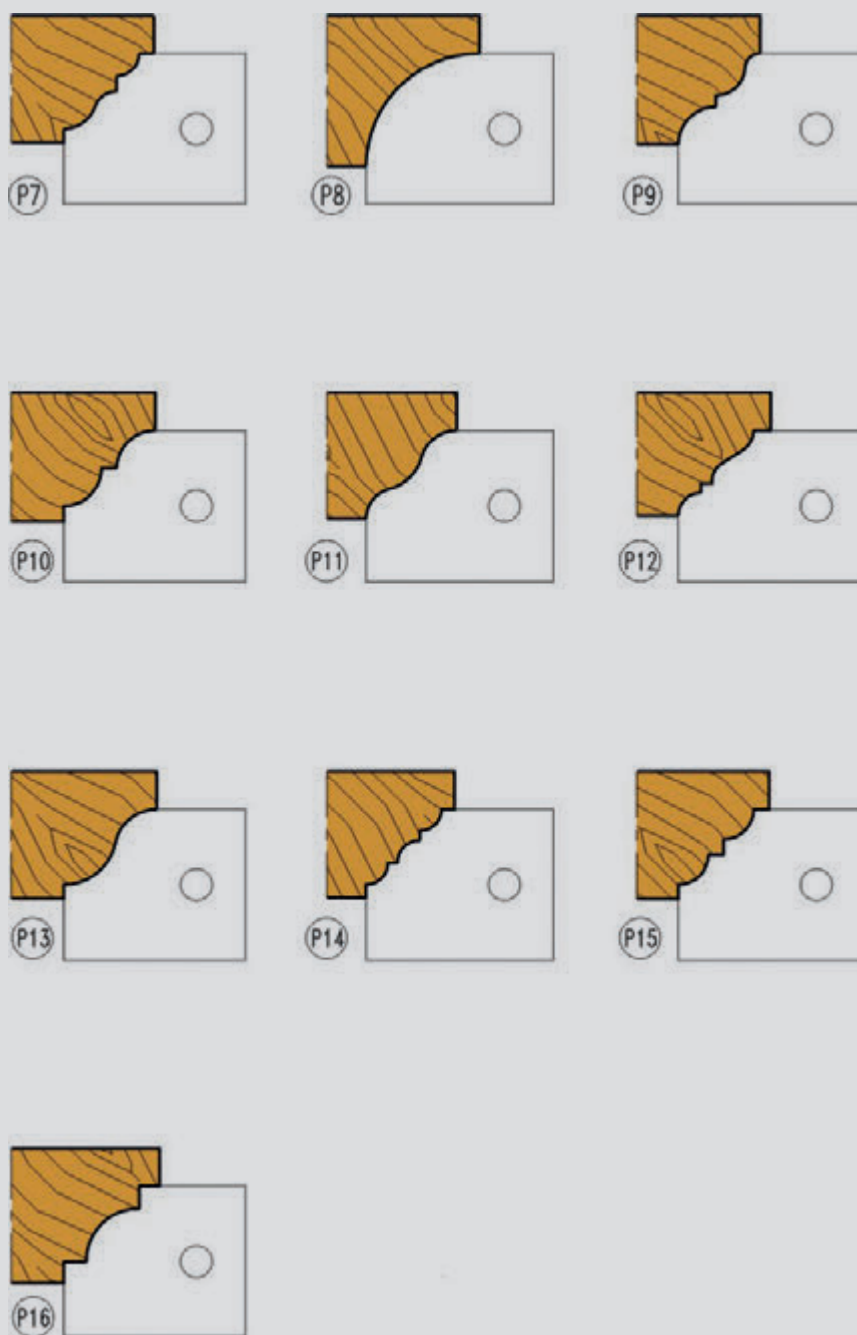

Universal profile cutterhead
Porte-outils multi-profil

unic-b

D	B	d	Z	n _{max.}	Ref.
140	20	50	3	9500	567.201 ○

MEC HW

567



○ Cutterhead supplied without knives - [Porte-outils livré sans plaquettes](#)

Spare parts - Pièces de rechange

		Dim.	Ref.
Knife - Plaquette	P1	20x30x2	785.651
	P2	20x30x2	785.652
	P3	20x30x2	785.653
	P4	20x30x2	785.654
	P5	20x30x2	785.655
	P6	20x30x2	785.656
	P7	20x30x2	785.657
	P8	20x30x2	785.658
	P9	20x30x2	785.659
	P10	20x30x2	785.660
	P11	20x30x2	785.661
	P12	20x30x2	785.662
	P13	20x30x2	785.663
	P14	20x30x2	785.664
	P15	20x30x2	785.665
	P16	20x30x2	785.666
	P17	20x30x2	785.667
	P18	20x30x2	785.668
Clamping wedge - Cale			707.086
Screw - Vis		M8x16	705.542
T Wrench - Clé en T		SW4	706.104

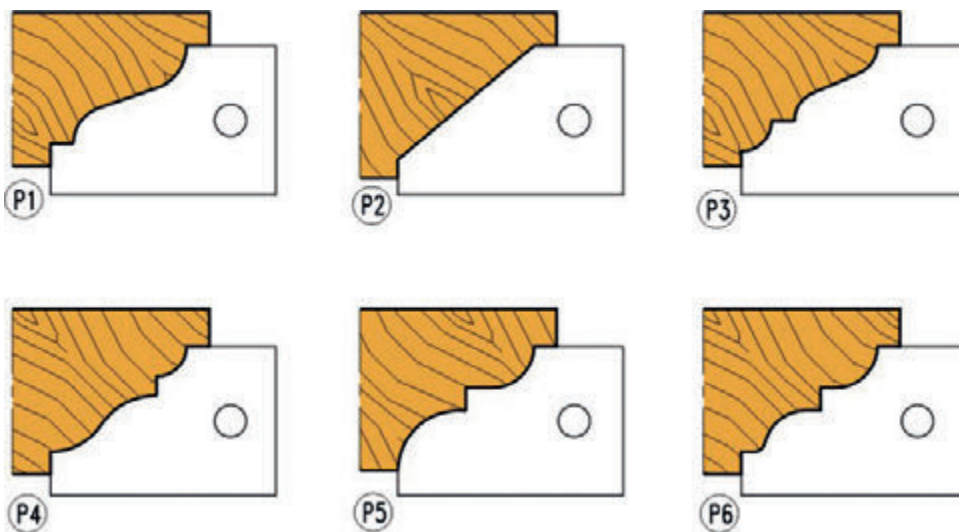



Universal profile cutterhead Porte-outils à profiler universel

D	B	d	Z		Ref.
138	40	30/50	3	8500	564.111
	50	30/50	3	8500	564.112
	60	30/50	3	8500	564.113

Knives and back support not included - *Porte-outils livré sans couteaux ni plaques d'appui.*

Spare parts - Pièces de rechange

	Dim.	Ref.
Clamping wedge - <i>Cale</i>	40	707.300.38
	50	707.300.48
	60	707.300.58
Screw - <i>Vis</i>	M8x16	705.542
T Wrench - <i>Clé en T</i>	SW4	706.104

Knives not profiled - Couteaux sans profil

	Dim.	Dmax.	Ref.	
	40	40x35x2	150	769.204
	50	50x35x2		769.206
	60	60x35x2		769.208
	40	40x40x2	160	769.214
	50	50x40x2		769.207
	60	60x40x2		769.209

Back support not profiled - plaquettes d'appui sans profil

	Dim.	Dmax.	Ref.	
	40	38x31x3,8	150	710.210
	50	48x31x3,8		710.211
	60	58x31x3,8		710.212
	40	38x36x3,8	160	710.220
	50	48x36x3,8		710.221
	60	58x36x3,8		710.222

MEC HW

564

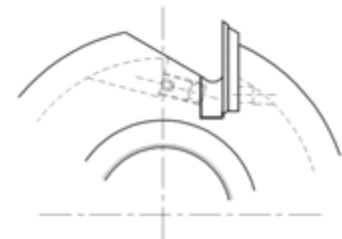
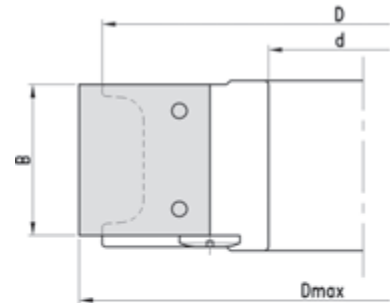

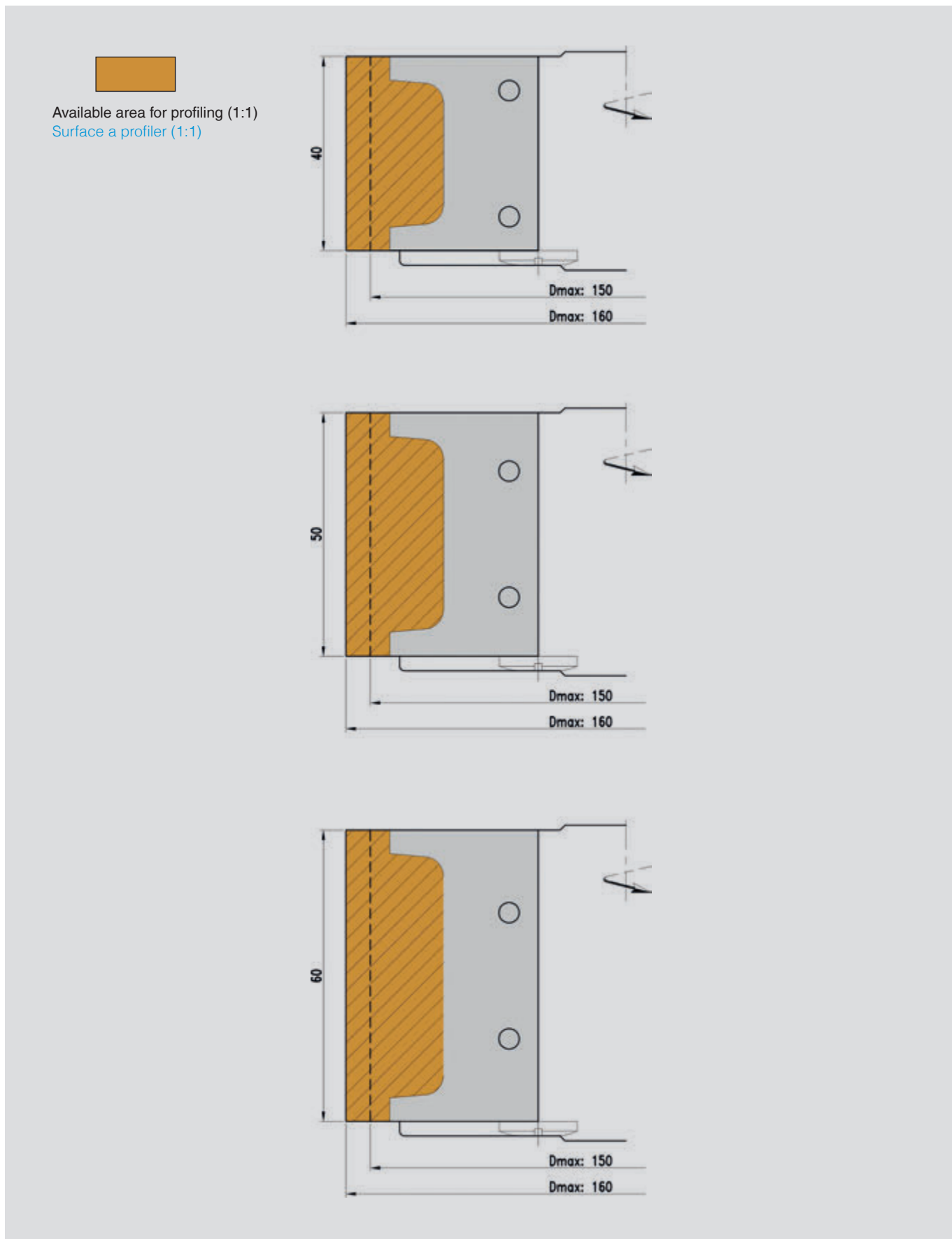

Moulding cutterhead PowerLock Porte-outils à profiler PowerLock

D	B	S	Z	n max.	Ref. LH/INF	Ref. RH/SUP
90	60	HSK 85WE	2	12000	601.101.61	601.201.61
	80	HSK 85WE	2	12000	601.102.61	601.202.61
	100	HSK 85WE	2	12000	601.103.61	601.203.61
	130	HSK 85WE	2	12000	601.104.61	601.204.61
	150	HSK 85WE	2	12000	601.105.61	601.205.61
	170	HSK 85WE	2	12000	601.106.61	601.206.61
	190	HSK 85WE	2	12000	601.107.61	601.207.61
	210	HSK 85WE	2	12000	601.108.61	601.208.61
	240	HSK 85WE	2	12000	601.109.61	601.209.61
90	60	HSK 85WE	4	12000	601.151.61	601.251.61
	80	HSK 85WE	4	12000	601.152.61	601.252.61
	100	HSK 85WE	4	12000	601.153.61	601.253.61
	130	HSK 85WE	4	12000	601.154.61	601.254.61
	150	HSK 85WE	4	12000	601.155.61	601.255.61
	170	HSK 85WE	4	12000	601.156.61	601.256.61
	190	HSK 85WE	4	12000	601.157.61	601.257.61
	210	HSK 85WE	4	12000	601.158.61	601.258.61
	240	HSK 85WE	4	12000	601.159.61	601.259.61

o Cutterhead supplied without knives - [Porte-outils livré sans plaquettes](#)

Spare parts - Pièces de rechange

	Dim.	Ref.
Screw - Vis	M12x20	705.556
T Wrench - Clé en T	SW6	706.106

We offer three different solutions for the planing and profiling work with PowerLock technology: Blank (rigidly body - monobloc), modular (adaptor cone HSK) and arbor HSK (for mounting) systems. For more details, please consult our commercial department.

Nous offrons trois différentes solutions pour profilage et rabotage avec la technologie PowerLock: système "blank" (corps monobloc), système modulaire (cône HSK attaché sûr l'outil) et système arbre porte fraises HSK pour montage des outils. Pour informations complémentaires, veuillez consulter notre département commercial.



MEC **HS**
HW

601



Recommended cutting material
[Matériel de coupe recommandée](#)

Softwood Pour bois tendres	HS
Hardwood Bois dur	HW

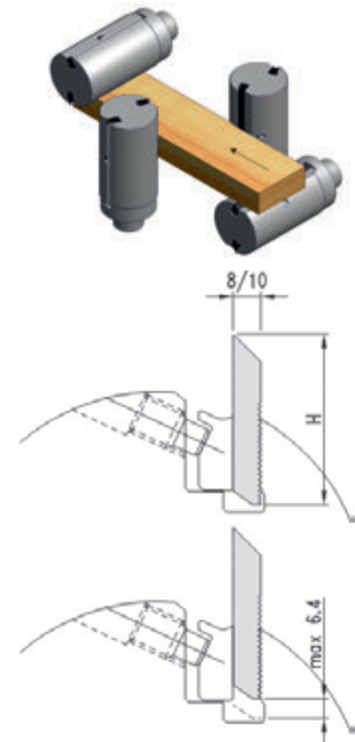

Maximum profile depth
[Profondeur du profil maximum](#)

Knife Couteaux	HS	HW
H=50	20	20
H=60	28	20
H=70	38	24

Moulding cutterhead Porte-outils à profiler

D	B	d	Z	n min.-max.	Ref.
122	40	30/40	2	4300-7400	573.101 ○
	60	30/40	2	4300-7400	573.102 ○
	80	30/40	2	4300-7400	573.103 ○
	100	30/40	2	4300-7400	573.104 ○

○ Cutterhead supplied without knives - [Porte-outils livré sans plaquettes](#)

Spare parts - Pièces de rechange

	Dim.	Ref.
Clamping wedge - Cale	40	707.853.40
	60	707.853.60
	80	707.853.80
	100	707.853.100
Screw - Vis	M12x20	705.556
T Wrench - Clé en T	SW6	706.106

MAN HS

573

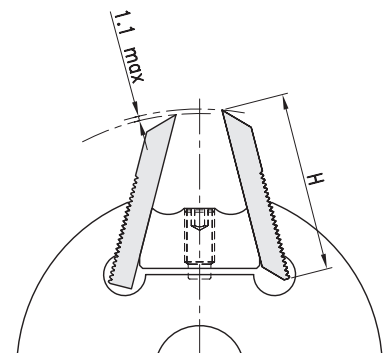
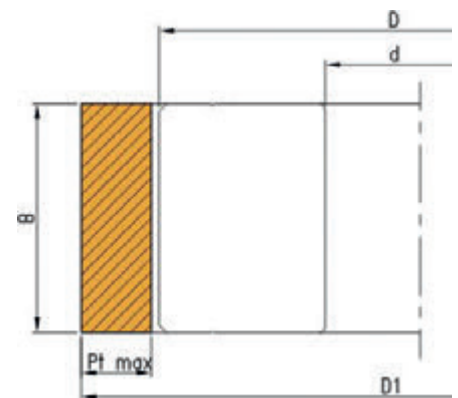
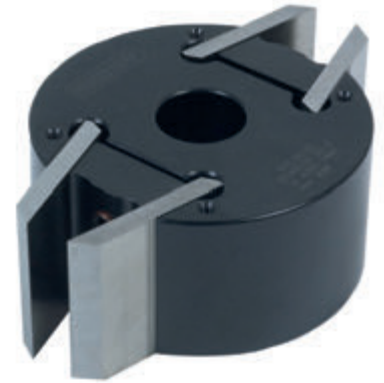

Maximum profile depth
[Profondeur maximum du profil](#)

Knife Couteaux	HS
H=50	15
H=60	25

Moulding cutterhead Porte-outils à profiler

D	B	d	Z	n _{max.}	Ref.
122	40	40	2	9000	501.101 ○
	60	40	2	9000	501.102 ○
	80	40	2	9000	501.103 ○
122	40	40	4	9000	501.301 ○
	60	40	4	9000	501.302 ○
	80	40	4	9000	501.303 ○
	100	40	4	9000	501.304 ○
	130	40	4	9000	501.305 ○
	150	40	4	9000	501.306 ○
	180	40	4	9000	501.307 ○
	230	40	4	9000	501.308 ○
137	40	50	4	9000	501.401 ○
	60	50	4	9000	501.402 ○
	80	50	4	9000	501.403 ○
	100	50	4	9000	501.404 ○
	130	50	4	9000	501.405 ○
	150	50	4	9000	501.406 ○
	180	50	4	9000	501.407 ○

○ Cutterhead supplied without knives - Porte-outils livré sans plaquettes

Spare parts - Pièces de rechange

	B	Dim.	Ref.
Clamping wedge - Cale	40		707.430
	60		707.431
	80		707.432
	100		707.433
	130		707.435
	150		707.436
	180		707.437
Blind wedge - Cale de garnissage	40		707.330
	60		707.331
	80		707.332
	100		707.333
	130		707.334
	150		707.335
	180		707.336
Screw - Vis		M12x20	705.556
T Wrench - Clé en T		SW6	706.106

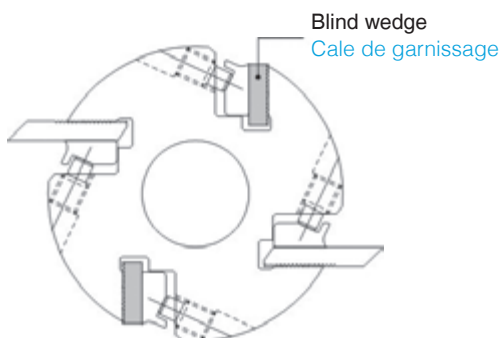

MEC HS
HW

501

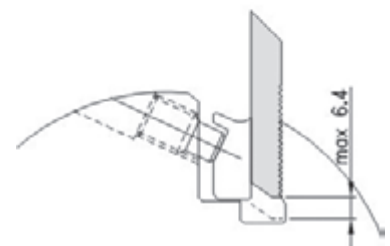
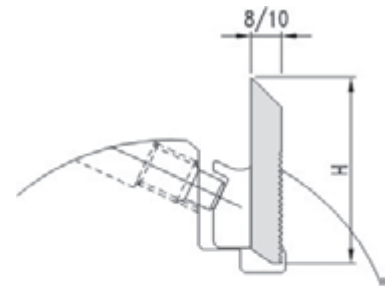
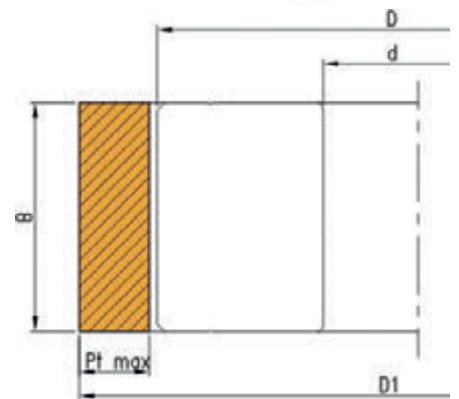

Maximum profile depth
Profondeur maximum du profil

Knife Couteaux	HS	HW
H=50	15	11
H=60	25	17
H=70	35	20

Maximum diameter D1
Diamètre maximum D1

Knife Couteaux	D1 (D122)	D1 (D137)
H=50	160	175
H=60	179	194
H=70	198	214



Hydro-Moulding cutterhead Porte-outils hydro à profiler

D	B	d	Z	n max.	Ref.	
137	60	40	4	9000	562.402 ○	
	100	40	4	9000	562.404 ○	
	130	40	4	9000	562.405 ○	
	150	40	4	9000	562.406 ○	
	180	40	4	9000	562.407 ○	
	230	40	4	9000	562.408 ○	
150	60	50	4	8000	562.412 ○	
	100	50	4	8000	562.414 ○	
	130	50	4	8000	562.415 ○	
	150	50	4	8000	562.416 ○	
	180	50	4	8000	562.417 ○	
	230	50	4	8000	562.418 ○	
150	60	50	6	8000	562.422 ○	
	100	50	6	8000	562.424 ○	
	130	50	6	8000	562.425 ○	
	150	50	6	8000	562.426 ○	
	180	50	6	8000	562.427 ○	
	230	50	6	8000	562.428 ○	
163	60	50	8	6000	562.432 ○	
	100	50	8	6000	562.434 ○	
	130	50	8	6000	562.435 ○	
	150	50	8	6000	562.436 ○	
	180	50	8	6000	562.437 ○	
	230	50	8	6000	562.438 ○	
new	190	60	50	12	6000	562.442 ○
new		80	50	12	6000	562.443 ○
new		100	50	12	6000	562.444 ○
new		130	50	12	6000	562.445 ○
new		150	50	12	6000	562.446 ○
new		180	50	12	6000	562.447 ○
new		230	50	12	6000	562.448 ○

○ Cutterhead supplied without knives - Porte-outils livré sans plaquettes

Spare parts - Pièces de rechange

	Dim.	Ref.
Clamping wedge - Cale	60	707.431
	100	707.433
	130	707.435
	150	707.436
	180	707.437
	230	707.439
Blind wedge - Cale de garnissage	60	707.431
	100	707.433
	130	707.434
	150	707.435
	180	707.436
Screw - Vis	M10x20	705.552.01
T Wrench - Clé en T	SW5	706.105
Grease pump - Pompe de chargement		724.401
Grease cartridge - Charge		724.402
Safety ring - Bague de sécurité		724.404



Recommended cutting material
Matériel de coupe recommandée

Softwood Pour bois tendres	HS
Hardwood Bois dur	HW

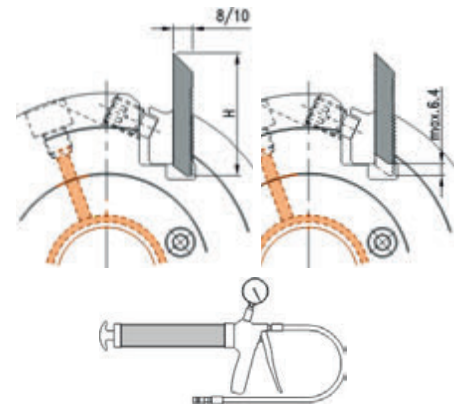

You should always use the safety ring 724.404 while setting up the cutter. See chapter 10.

Utiliser toujours la bague de sécurité 724.404 pour montage du porte-outils hydro. Voir le chapitre 10.

Maximum profile depth

Profondeur maximum du profil

Knife Couteaux	HS	HW
H=50	15	10
H=60	25	15
H=70	35	18

Maximum diameter

Diamètre maximum

Knife Couteaux	Dmax (D137)	Dmax (D150)	Dmax (D163)
H=50	175	190	200
H=60	195	205	220
H=70	215	225	240

Pressure nipple
schéma:
Schéma pour
la distribution
de pression:

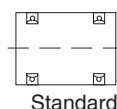

Standard

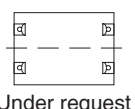

Under request
Sur demande

Universal cutterhead with profiled knives Porte-outils universel à couteaux profilés

With 2 rebate Knives - Avec 2 plaquettes à dresser

D	B	d	Z	n _{max.}	Ref.
100	40	30	2	9000	590.102
120	40	50	2	9000	590.202

Set complete in box - Jeu complet avec coffret

D	B	d	Z	Knife Plaquette	n _{max.}	Ref.
100	40	30	2	1- 6	9000	590.004
	40	30	2	1-12	9000	590.003
	40	30	2	9/12/14/15/19/36	9000	590.008
120	40	50	2	1- 6	9000	590.024
	40	50	2	1-12	9000	590.023
	40	50	2	9/12/14/15/19/36	9000	590.028

MEC SP

590

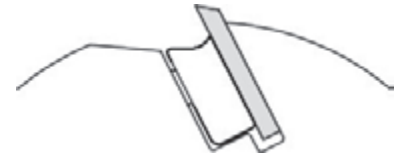

With 2 rebate Knives - Avec 2 plaquettes à dresser

D	B	d	Z	n _{min.-max.}	Ref.
100	40	30	2	6000-9000	590.101
120	40	50	2	6000-9000	590.201

Set complete in box - Jeu complet avec coffret

D	B	d	Z	Knife Plaquette	n _{max.}	Ref.
100	40	30	2	1- 6	6000-9000	590.002
	40	30	2	1-12	6000-9000	590.001
	40	30	2	9/12/14/15/19/36	6000-9000	590.009
120	40	50	2	1- 6	6000-9000	590.022
	40	50	2	1-12	6000-9000	590.021
	40	50	2	9/12/14/15/19/36	6000-9000	590.029

MAN SP

3



Spare parts - Pièces de rechange

	Nr.	Dim.	Ref.
Clamping wedge - Cale	1		707.850
	2		707.851
Screw - Vis	1	M10x20	705.552
	2	M10x16	705.551
T Wrench - Clé en T		SW5	706.105
Knife for profiling - Couteaux profil			778.000
Deflector for profiling - Limiteurs profil			778.001

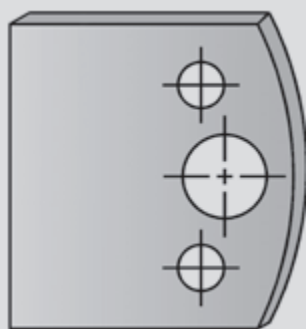

Knife - Couteau 778.100
Deflector - Limiteur 778.200

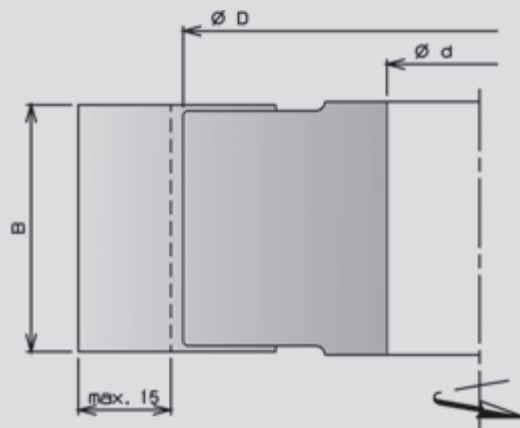

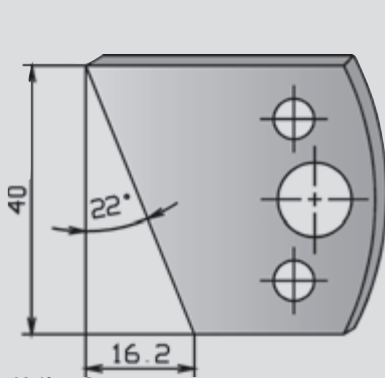

Knife - Couteau 778.101
 Deflector - Limiteur 778.201

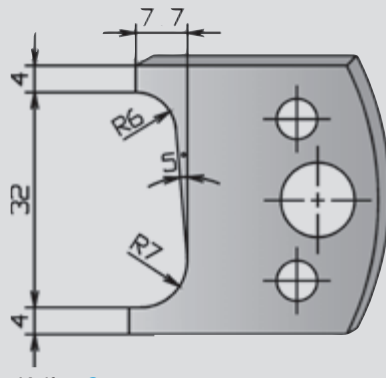

Knife - Couteau 778.102
 Deflector - Limiteur 778.202

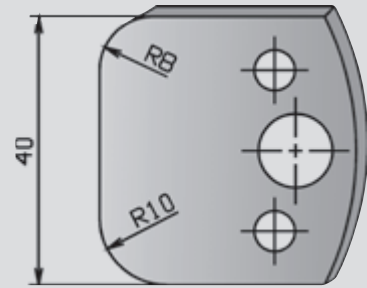

Knife - Couteau 778.103
 Deflector - Limiteur 778.203

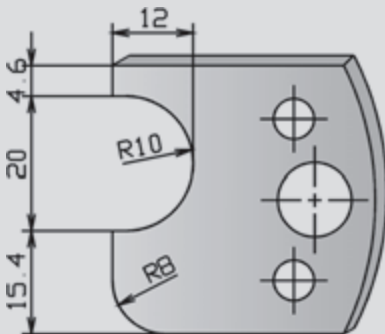

Knife - Couteau 778.104
 Deflector - Limiteur 778.204

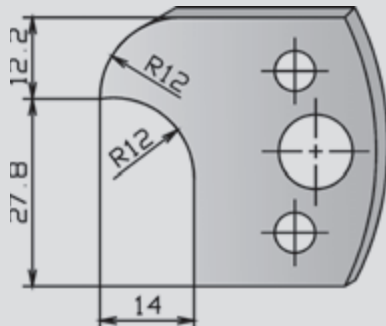

Knife - Couteau 778.105
 Deflector - Limiteur 778.205

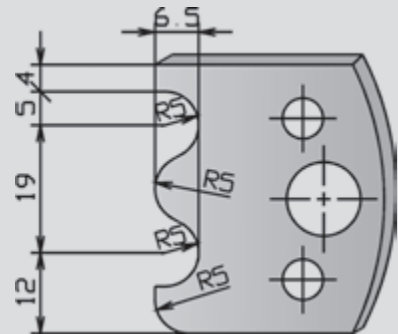

Knife - Couteau 778.106
 Deflector - Limiteur 778.206

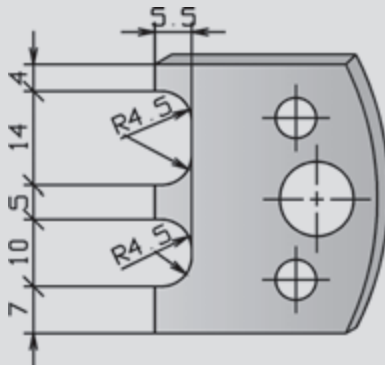

Knife - Couteau 778.107
 Deflector - Limiteur 778.207

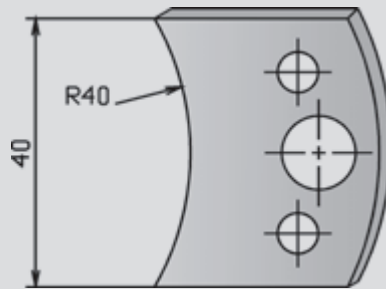

Knife - Couteau 778.108
 Deflector - Limiteur 778.208

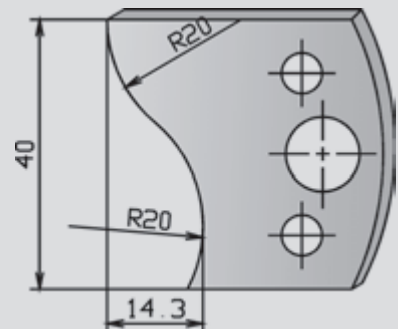

Knife - Couteau 778.109
 Deflector - Limiteur 778.209

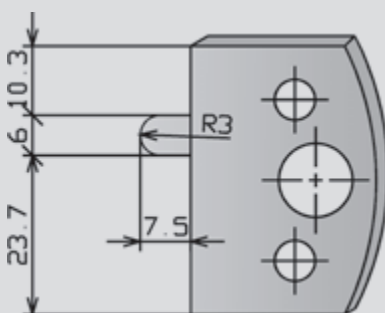

Knife - Couteau 778.110
 Deflector - Limiteur 778.210

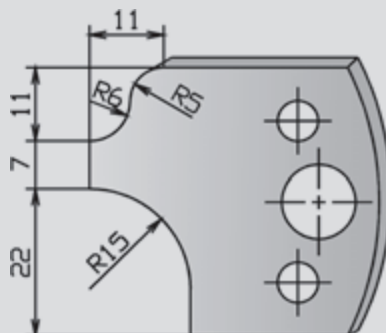

Knife - Couteau 778.111
 Deflector - Limiteur 778.211

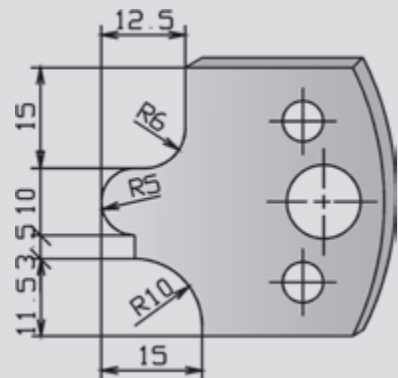

Knife - Couteau 778.112
 Deflector - Limiteur 778.212

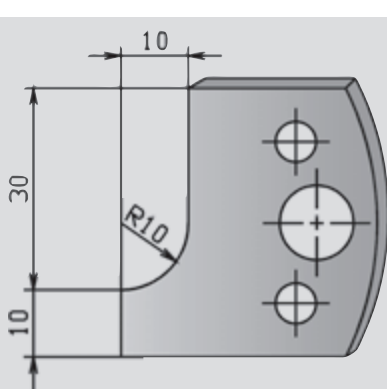

Knife - Couteau 778.113
 Deflector - Limiteur 778.213

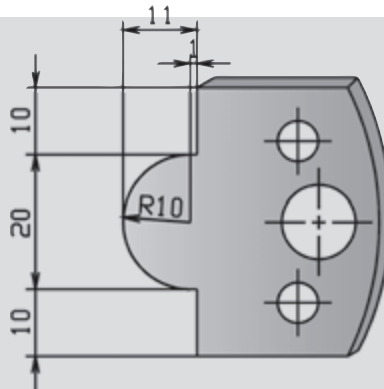

Knife - Couteau 778.114
 Deflector - Limiteur 778.214

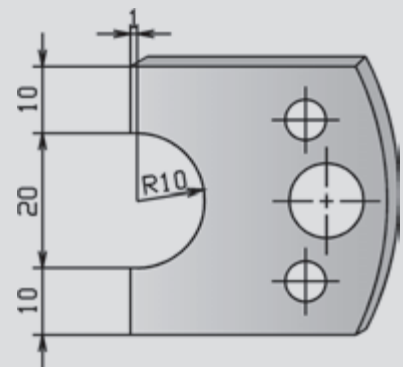

Knife - Couteau 778.115
 Deflector - Limiteur 778.215

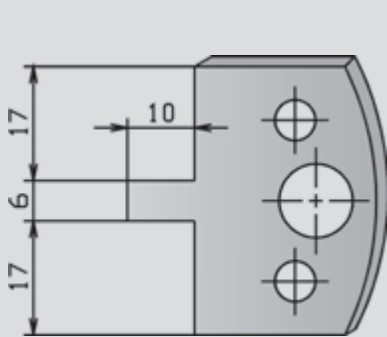

Knife - Couteau 778.116
 Deflector - Limiteur 778.216

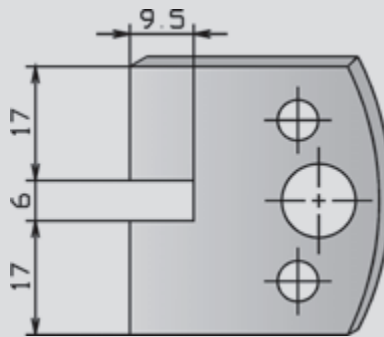

Knife - Couteau 778.117
 Deflector - Limiteur 778.217

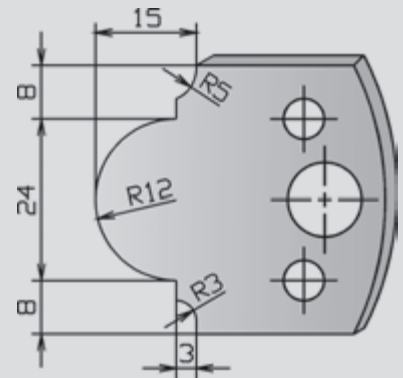

Knife - Couteau 778.118
 Deflector - Limiteur 778.218

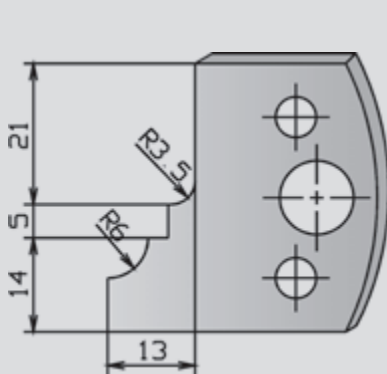

Knife - Couteau 778.119
 Deflector - Limiteur 778.219

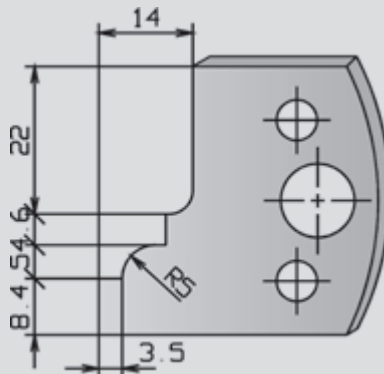

Knife - Couteau 778.120
 Deflector - Limiteur 778.220

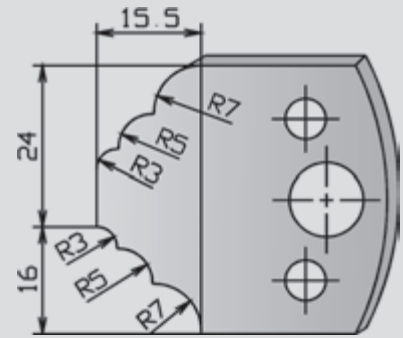

Knife - Couteau 778.121
 Deflector - Limiteur 778.221

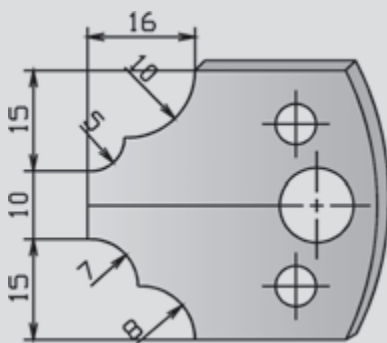

Knife - Couteau 778.122
 Deflector - Limiteur 778.222

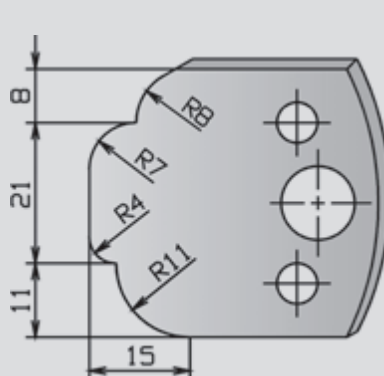

Knife - Couteau 778.123
 Deflector - Limiteur 778.223

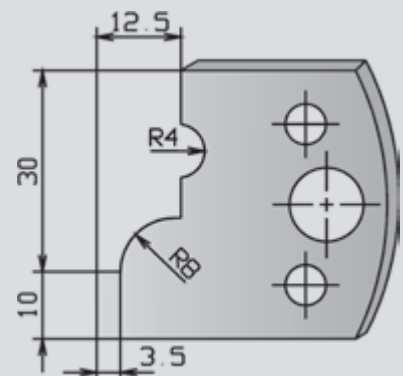

Knife - Couteau 778.124
 Deflector - Limiteur 778.224



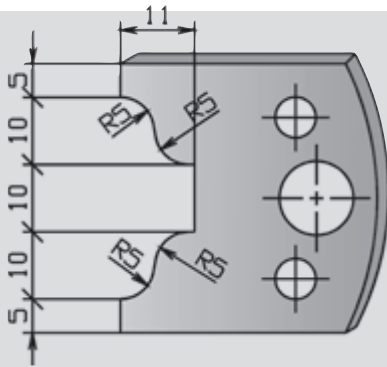

Knife - Couteau 778.125
 Deflector - Limiteur 778.225

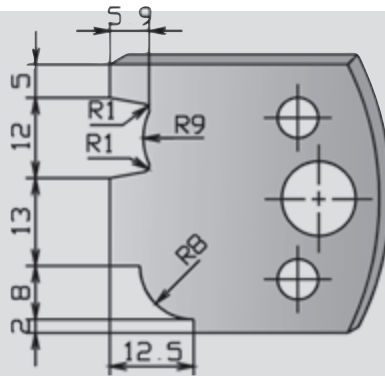

Knife - Couteau 778.126
 Deflector - Limiteur 778.226

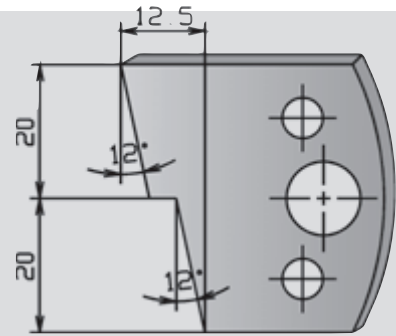

Knife - Couteau 778.127
 Deflector - Limiteur 778.227

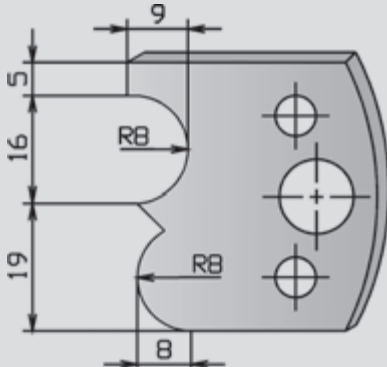

Knife - Couteau 778.128
 Deflector - Limiteur 778.228

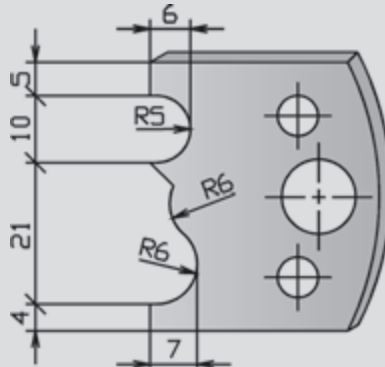

Knife - Couteau 778.129
 Deflector - Limiteur 778.229

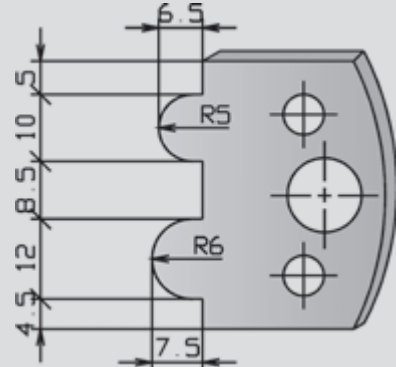

Knife - Couteau 778.130
 Deflector - Limiteur 778.230

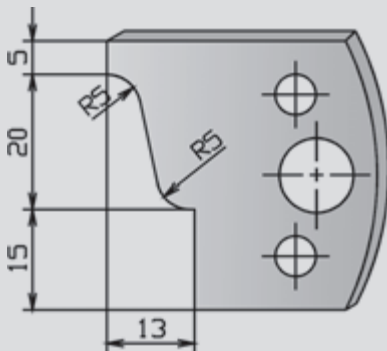

Knife - Couteau 778.131
 Deflector - Limiteur 778.231

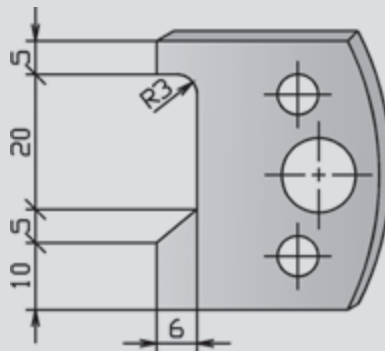

Knife - Couteau 778.132
 Deflector - Limiteur 778.232

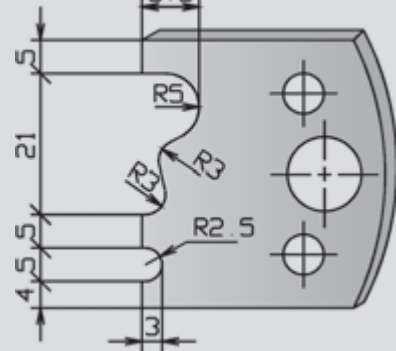

Knife - Couteau 778.133
 Deflector - Limiteur 778.233

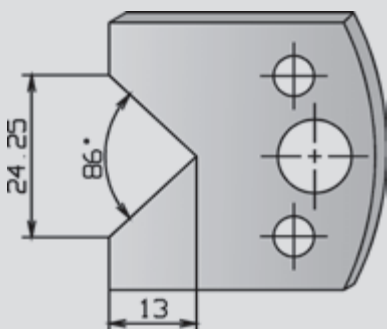

Knife - Couteau 778.134
 Deflector - Limiteur 778.234

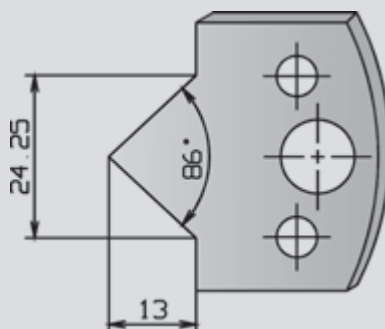

Knife - Couteau 778.135
 Deflector - Limiteur 778.235

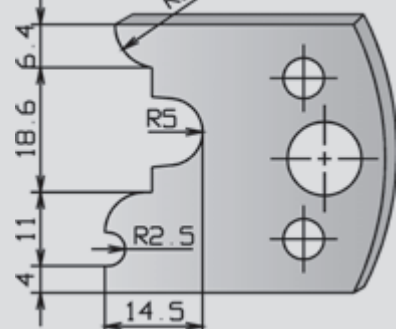

Knife - Couteau 778.136
 Deflector - Limiteur 778.236

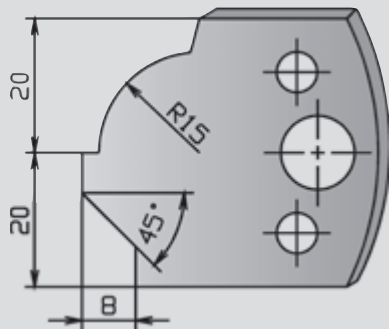

Knife - Couteau 778.137
 Deflector - Limiteur 778.237

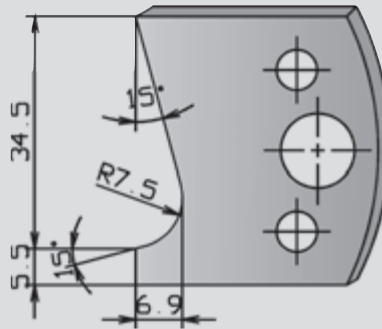

Knife - Couteau 778.138
 Deflector - Limiteur 778.238

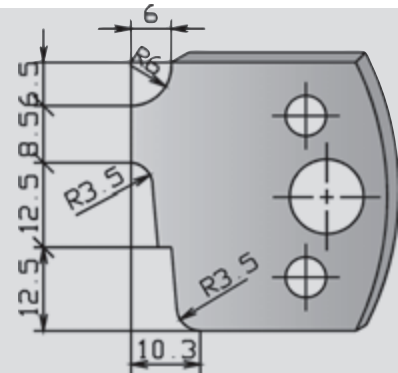

Knife - Couteau 778.139
 Deflector - Limiteur 778.239

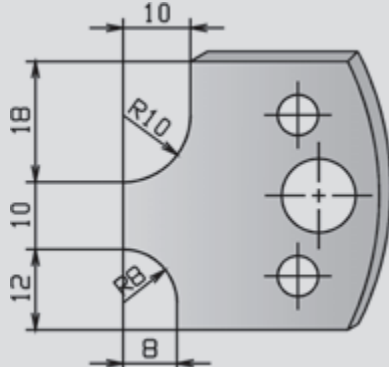

Knife - Couteau 778.140
 Deflector - Limiteur 778.240

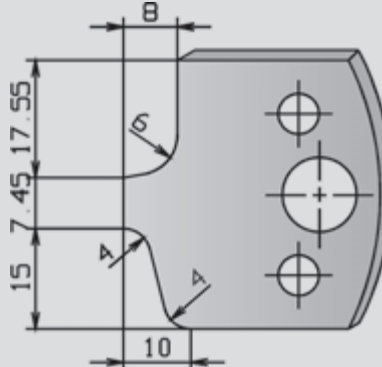

Knife - Couteau 778.141
 Deflector - Limiteur 778.241

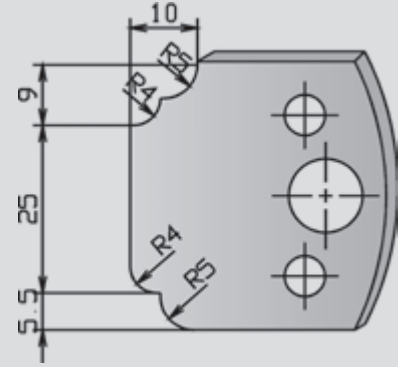

Knife - Couteau 778.142
 Deflector - Limiteur 778.242

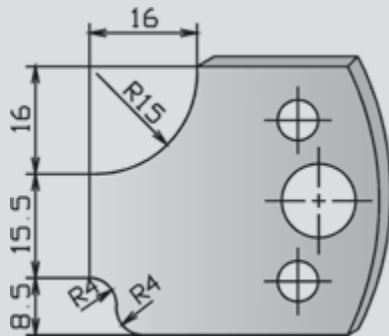

Knife - Couteau 778.143
 Deflector - Limiteur 778.243

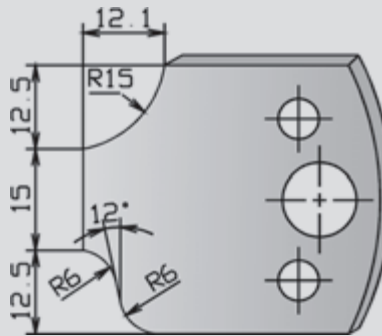

Knife - Couteau 778.144
 Deflector - Limiteur 778.244

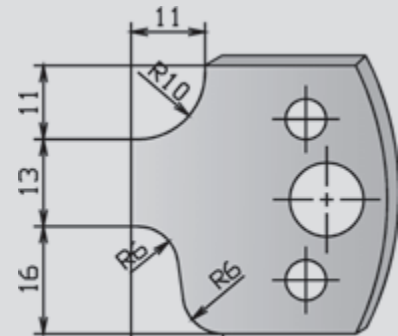

Knife - Couteau 778.145
 Deflector - Limiteur 778.245

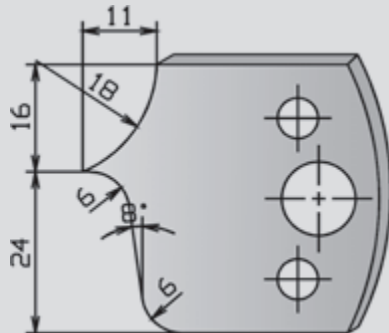

Knife - Couteau 778.146
 Deflector - Limiteur 778.246

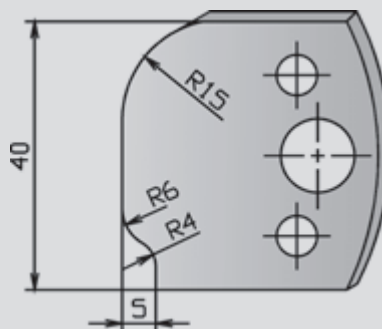

Knife - Couteau 778.147
 Deflector - Limiteur 778.247

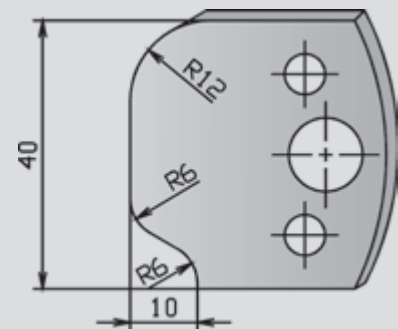

Knife - Couteau 778.148
 Deflector - Limiteur 778.248



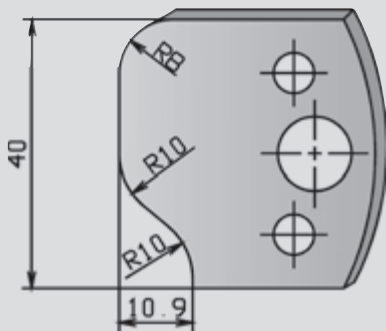

Knife - Couteau 778.149
 Deflector - Limiteur 778.249

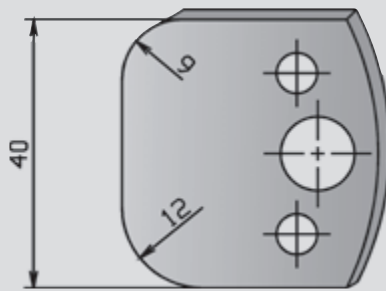

Knife - Couteau 778.150
 Deflector - Limiteur 778.250

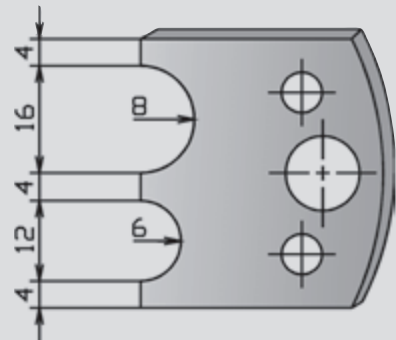

Knife - Couteau 778.151
 Deflector - Limiteur 778.251

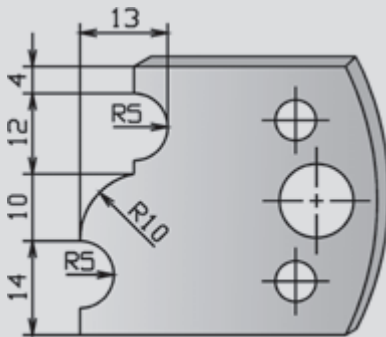

Knife - Couteau 778.152
 Deflector - Limiteur 778.252

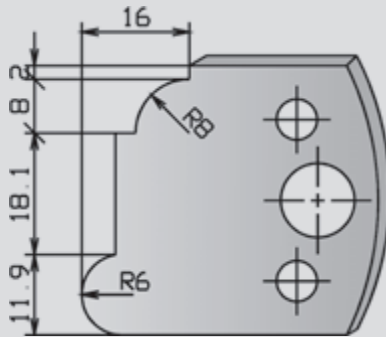

Knife - Couteau 778.153
 Deflector - Limiteur 778.253

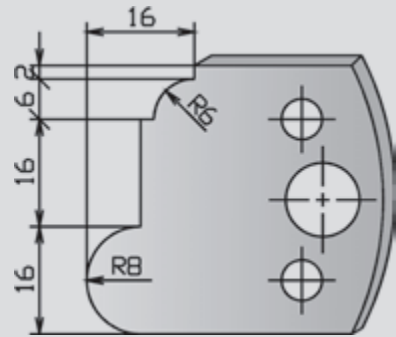

Knife - Couteau 778.154
 Deflector - Limiteur 778.254

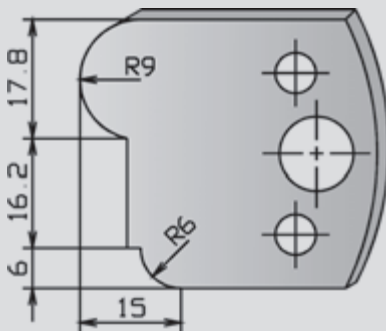

Knife - Couteau 778.155
 Deflector - Limiteur 778.255

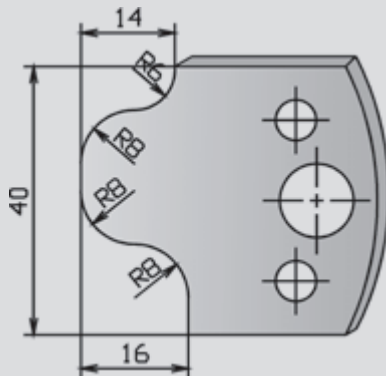

Knife - Couteau 778.156
 Deflector - Limiteur 778.256

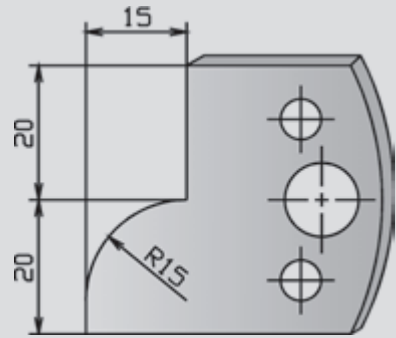

Knife - Couteau 778.157
 Deflector - Limiteur 778.257

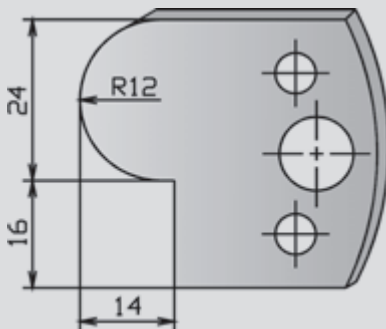

Knife - Couteau 778.158
 Deflector - Limiteur 778.258

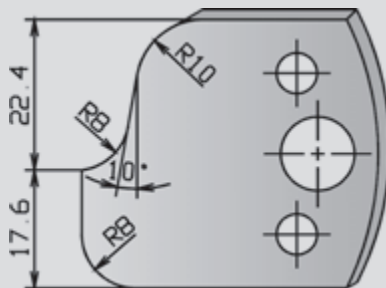

Knife - Couteau 778.159
 Deflector - Limiteur 778.259

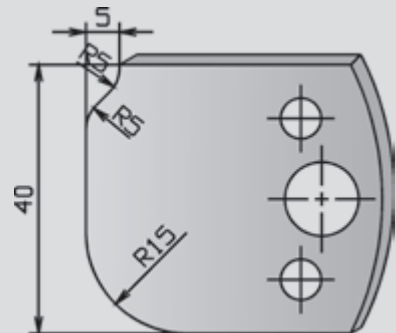

Knife - Couteau 778.160
 Deflector - Limiteur 778.260

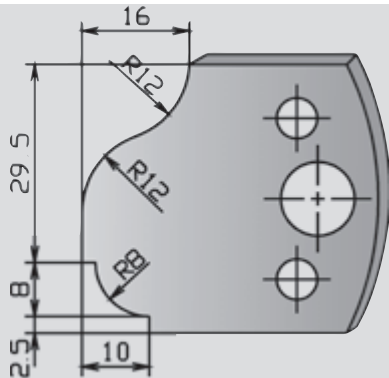

Knife - Couteau 778.161
 Deflector - Limiteur 778.261

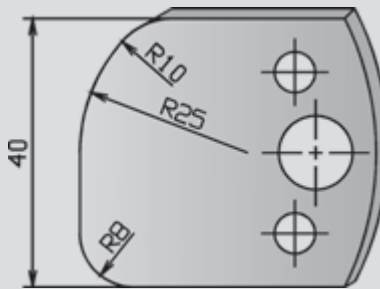

Knife - Couteau 778.162
 Deflector - Limiteur 778.262

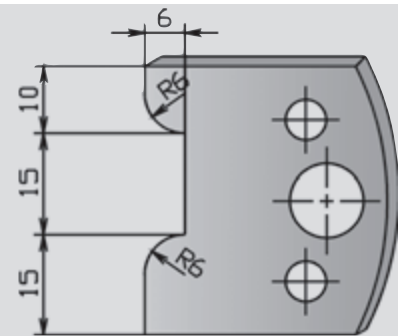

Knife - Couteau 778.163
 Deflector - Limiteur 778.263

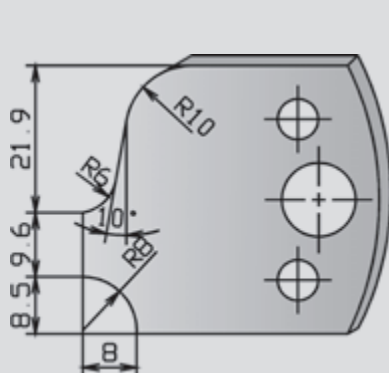

Knife - Couteau 778.164
 Deflector - Limiteur 778.264

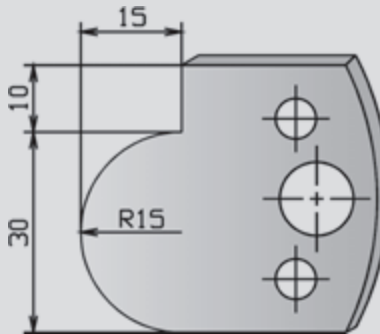

Knife - Couteau 778.165
 Deflector - Limiteur 778.265

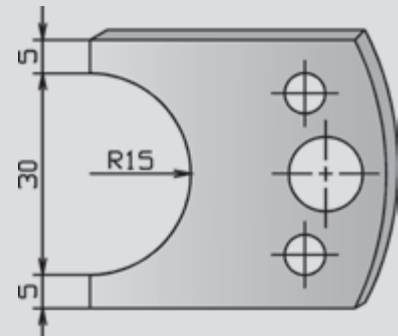

Knife - Couteau 778.166
 Deflector - Limiteur 778.266

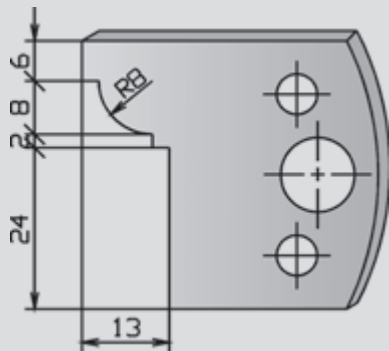

Knife - Couteau 778.167
 Deflector - Limiteur 778.267

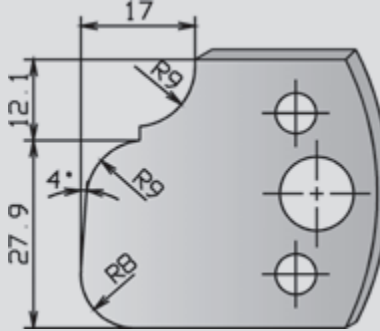

Knife - Couteau 778.168
 Deflector - Limiteur 778.268

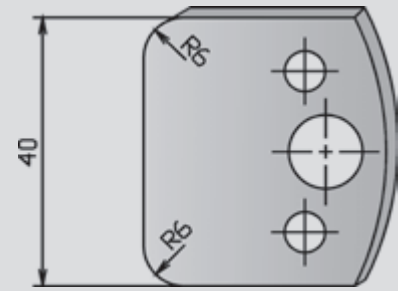

Knife - Couteau 778.169
 Deflector - Limiteur 778.269

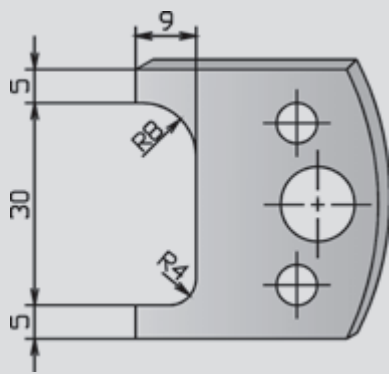

Knife - Couteau 778.170
 Deflector - Limiteur 778.270

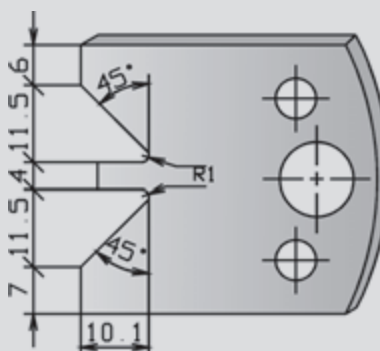

Knife - Couteau 778.171
 Deflector - Limiteur 778.271

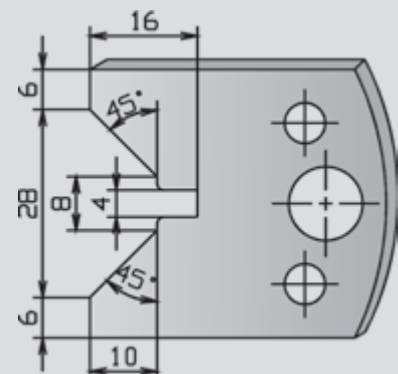

Knife - Couteau 778.172
 Deflector - Limiteur 778.272



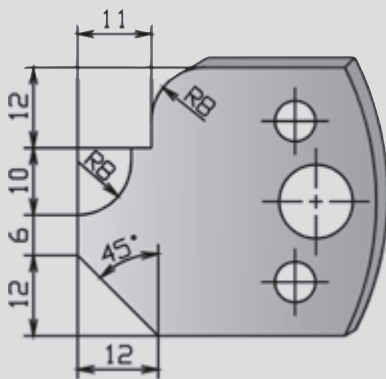

Knife - Couteau 778.173
 Deflector - Limiteur 778.273

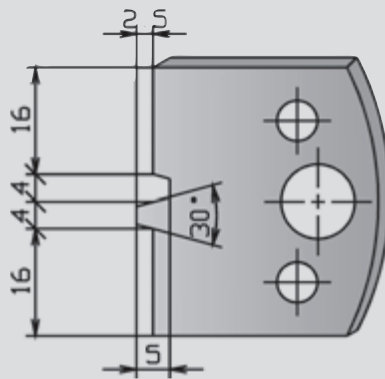

Knife - Couteau 778.174
 Deflector - Limiteur 778.274

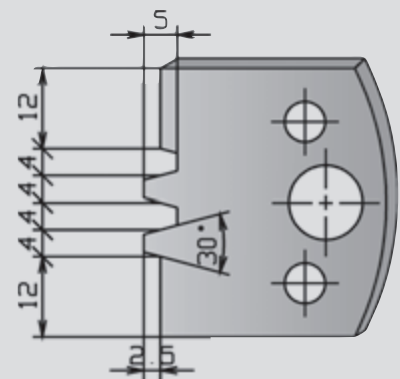

Knife - Couteau 778.175
 Deflector - Limiteur 778.275

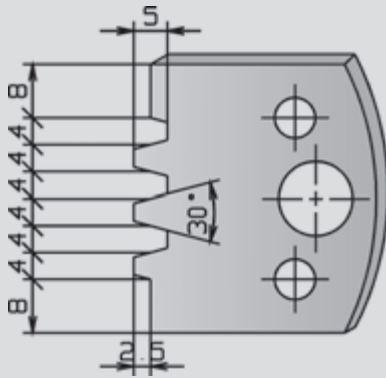

Knife - Couteau 778.176
 Deflector - Limiteur 778.276

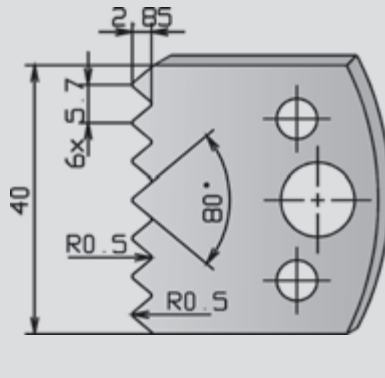

Knife - Couteau 778.177
 Deflector - Limiteur 778.277

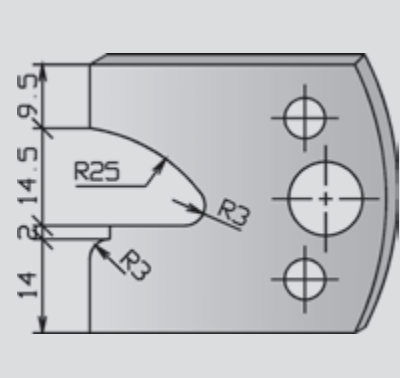

Knife - Couteau 778.178
 Deflector - Limiteur 778.278

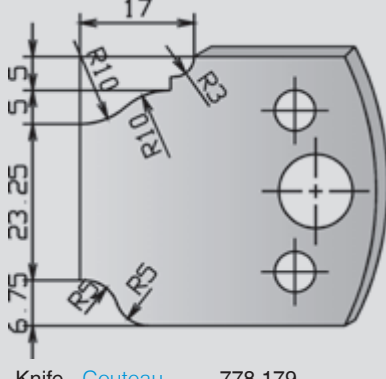

Knife - Couteau 778.179
 Deflector - Limiteur 778.279

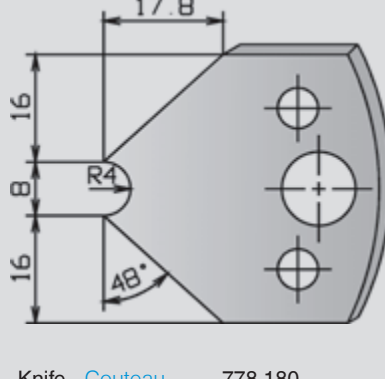

Knife - Couteau 778.180
 Deflector - Limiteur 778.280

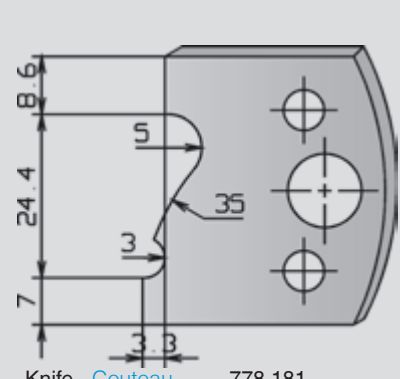

Knife - Couteau 778.181
 Deflector - Limiteur 778.281

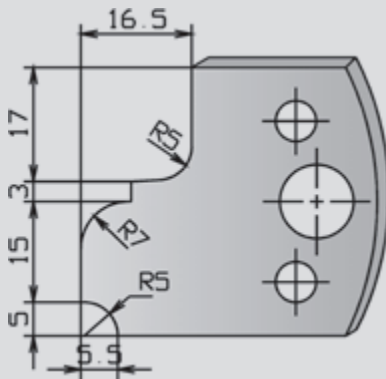

Knife - Couteau 778.182
 Deflector - Limiteur 778.282

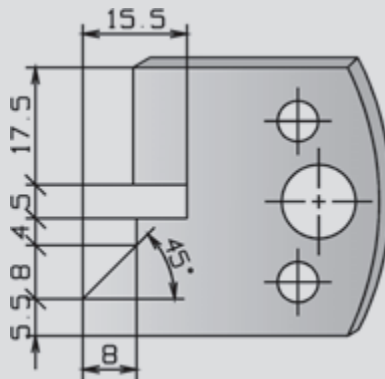

Knife - Couteau 778.183
 Deflector - Limiteur 778.283

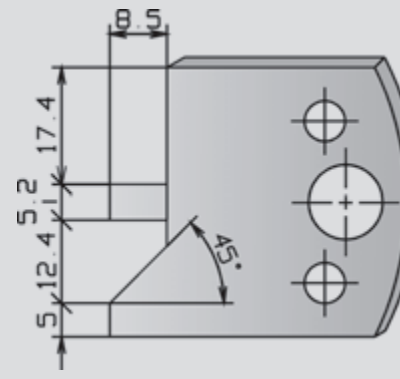

Knife - Couteau 778.184
 Deflector - Limiteur 778.284

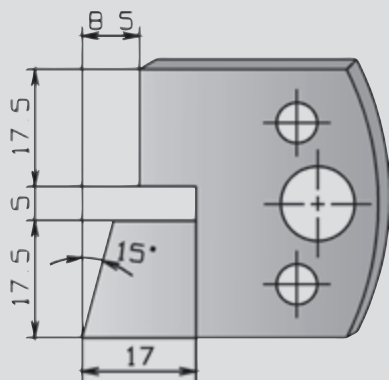

Knife - Couteau 778.185
 Deflector - Limiteur 778.285

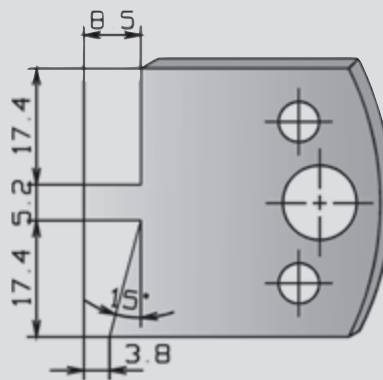

Knife - Couteau 778.186
 Deflector - Limiteur 778.286

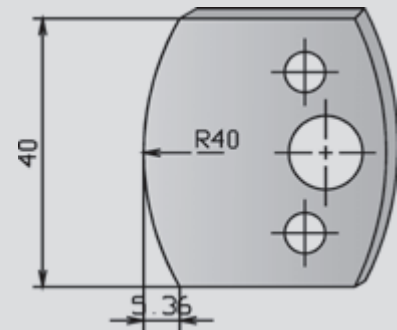

Knife - Couteau 778.187
 Deflector - Limiteur 778.287

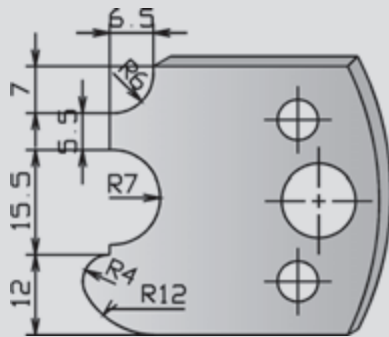

Knife - Couteau 778.188
 Deflector - Limiteur 778.288

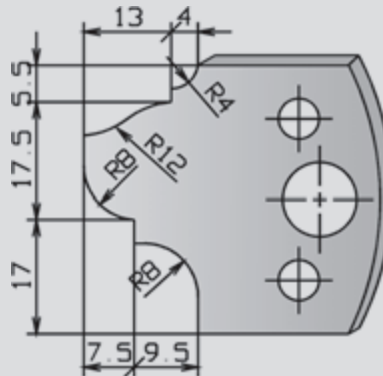

Knife - Couteau 778.189
 Deflector - Limiteur 778.289

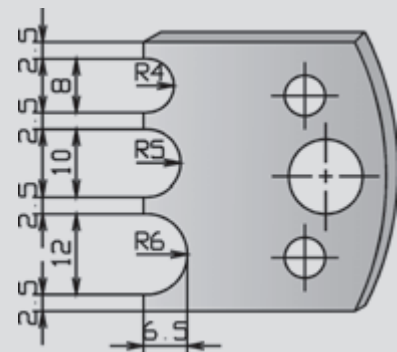

Knife - Couteau 778.190
 Deflector - Limiteur 778.290

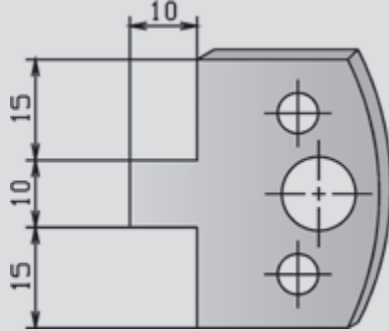

Knife - Couteau 778.191
 Deflector - Limiteur 778.291

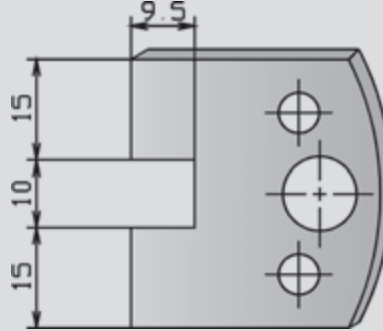

Knife - Couteau 778.192
 Deflector - Limiteur 778.292

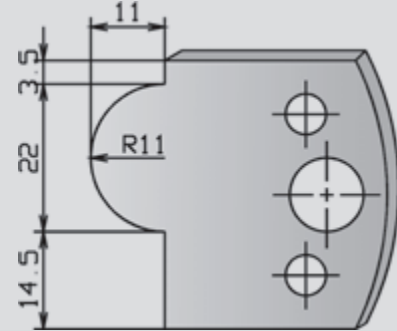

Knife - Couteau 778.193
 Deflector - Limiteur 778.293

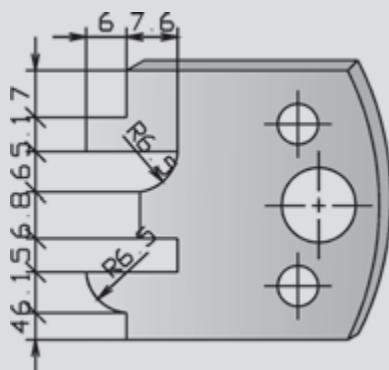

Knife - Couteau 778.194
 Deflector - Limiteur 778.294

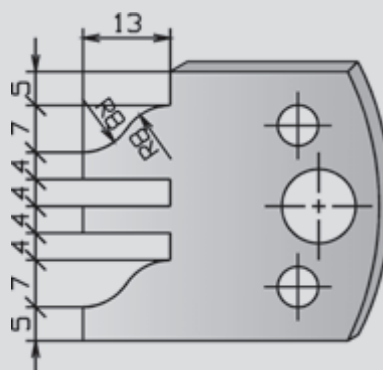

Knife - Couteau 778.195
 Deflector - Limiteur 778.295

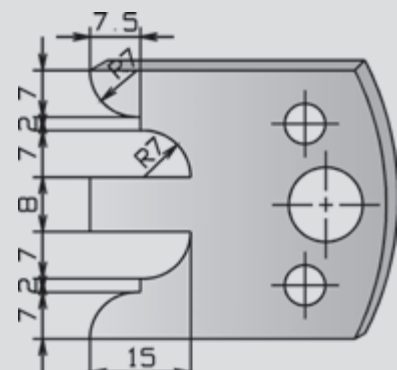

Knife - Couteau 778.196
 Deflector - Limiteur 778.296



Profile cutterset
Jeu de fraises profil

Nr	D	B	d	Z	n ⁿ min.-max.	Ref.
1	168	48	30/50	2	5700-7000	235.101
2	190	38	30/50	2	5700-7000	235.201
3	174	50	30/50	2	5700-7000	235.301
4	134	42	30/50	2	5700-7000	235.401
1+2+3+4						235.001

MAN HW

235

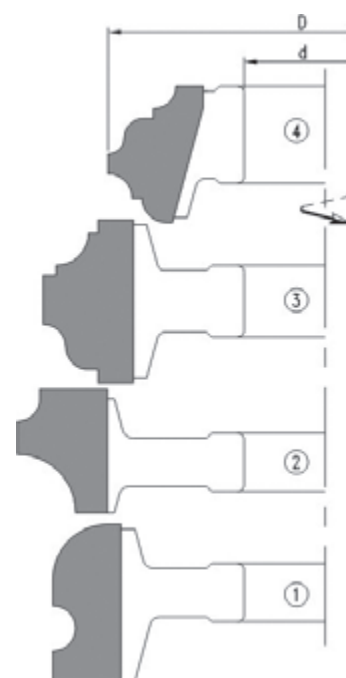
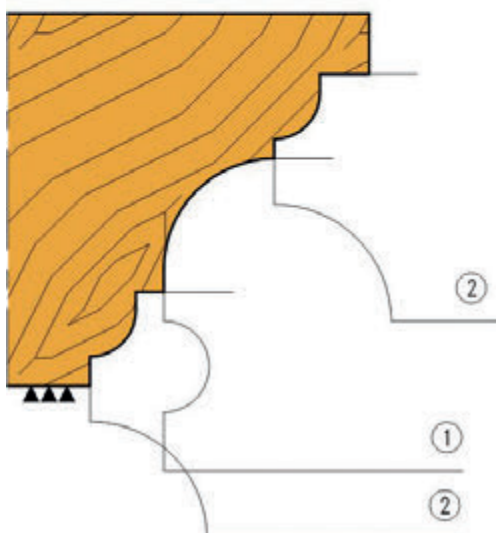
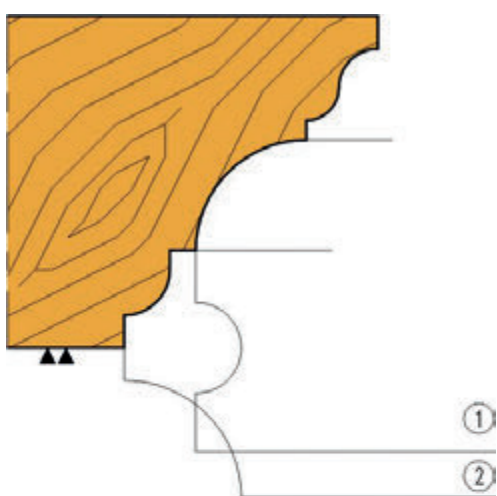

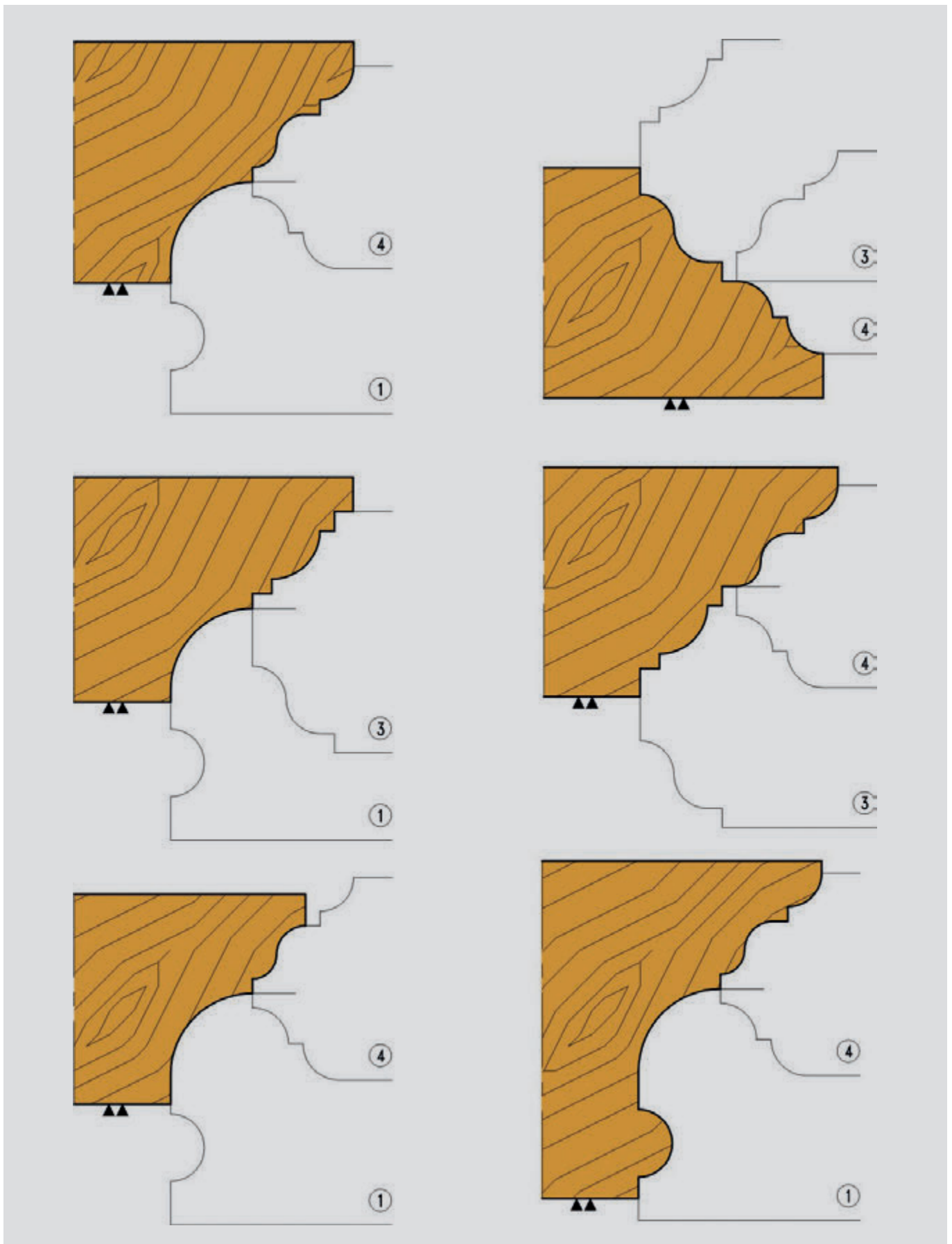

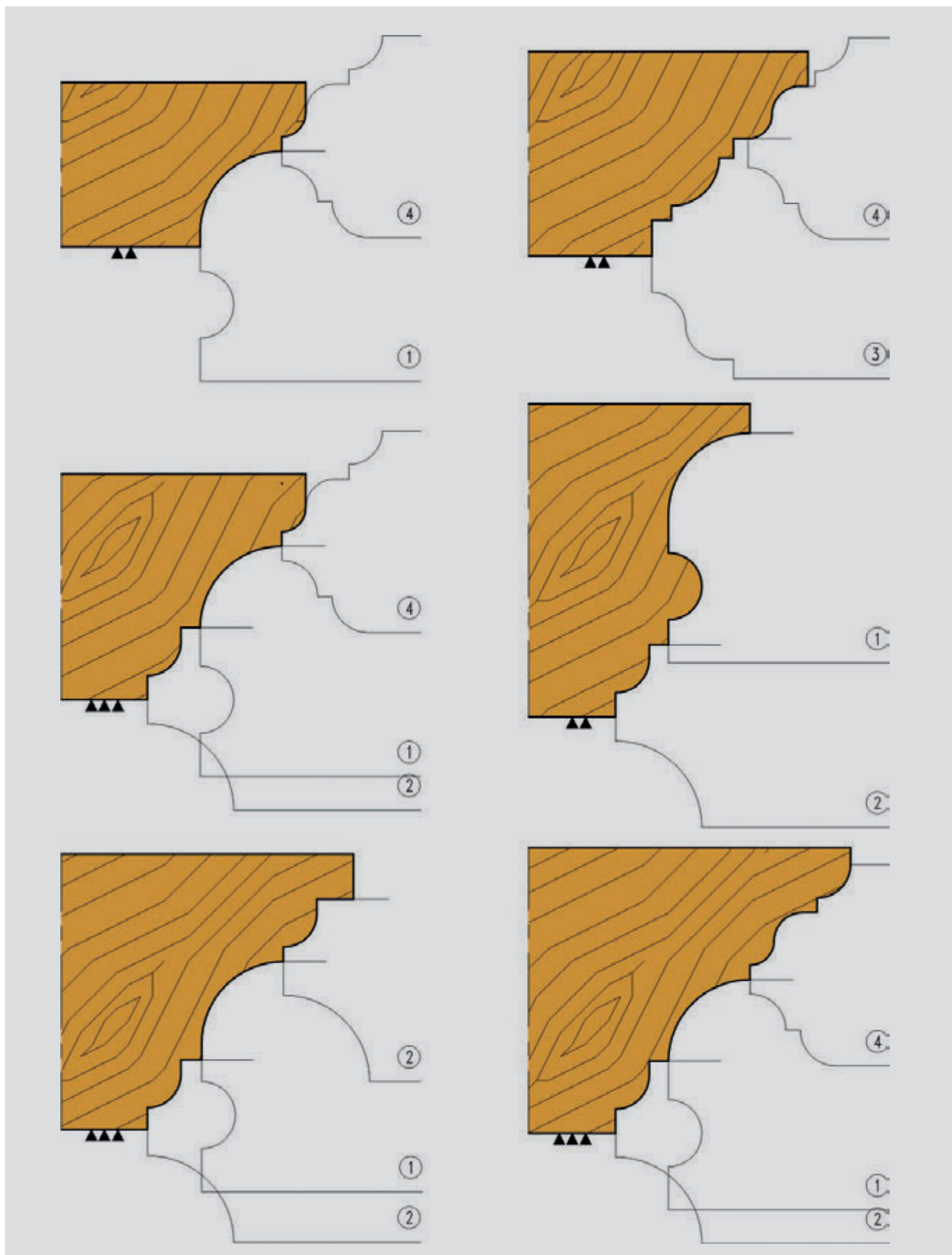

Profile cutterblock
Fraise-Profil

Nr	D	B	d	Z	n _{min.-max.}	Ref.
3	140	24	30/50	3	5500-9500	240.103
7		18	30/50	3	5500-9500	240.110
8		22	30/50	3	5500-9500	240.111

MAN HW

240

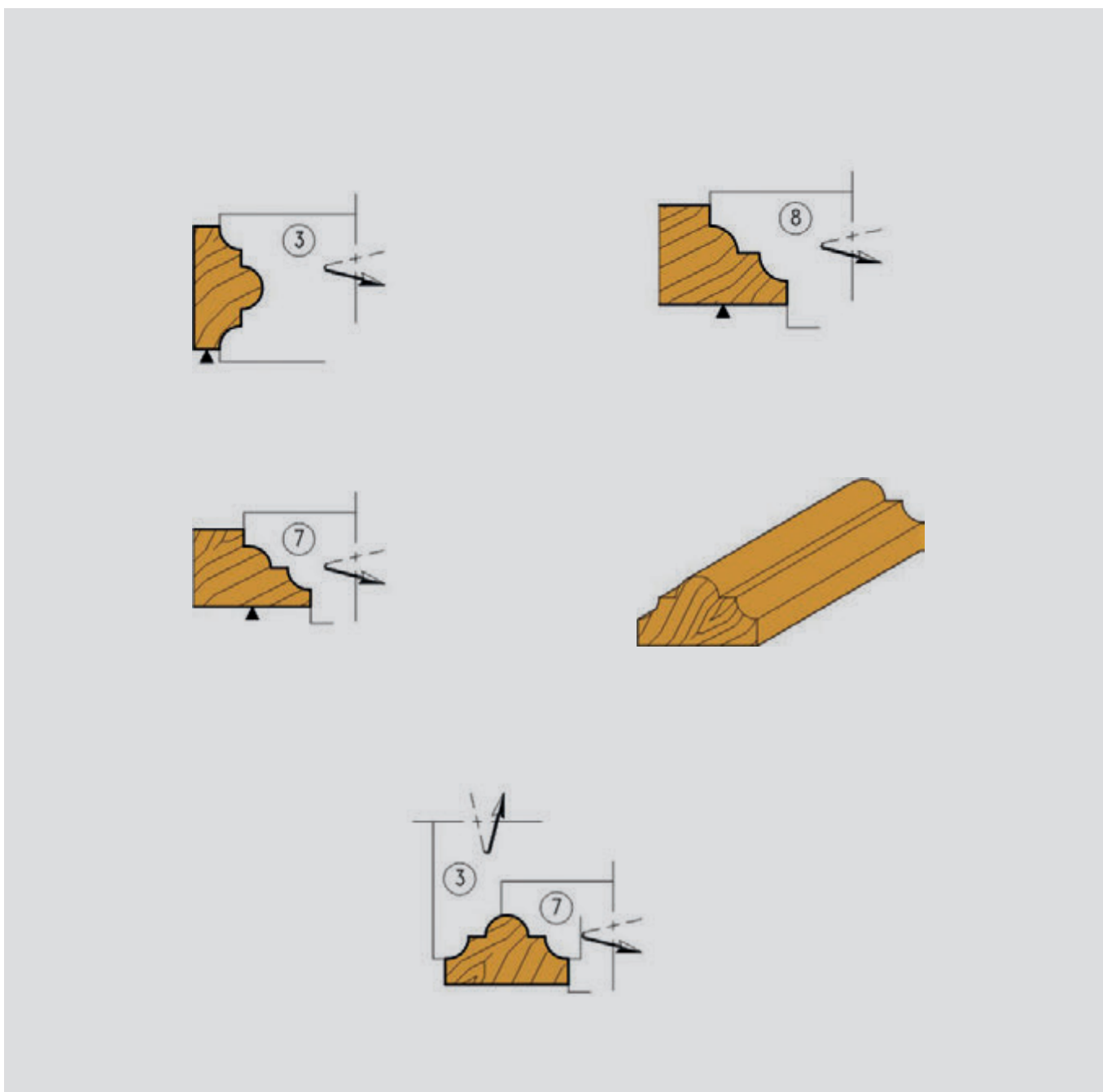

Profile cutterblock
Fraise-Profil

Nr	D	B	d	Z	n _{min.-max.}	Ref.
1	140	45	30/50	3	5500-9500	239.101
4		45	30/50	3	5500-9500	239.104
5		40	30/50	3	5500-9500	239.105
6		34	30/50	3	5500-9500	239.106
9		65	30/50	3	5500-9500	239.109
17		45	30/50	3	5500-9500	239.117
18		50	30/50	3	5500-9500	239.118

MAN HW

239

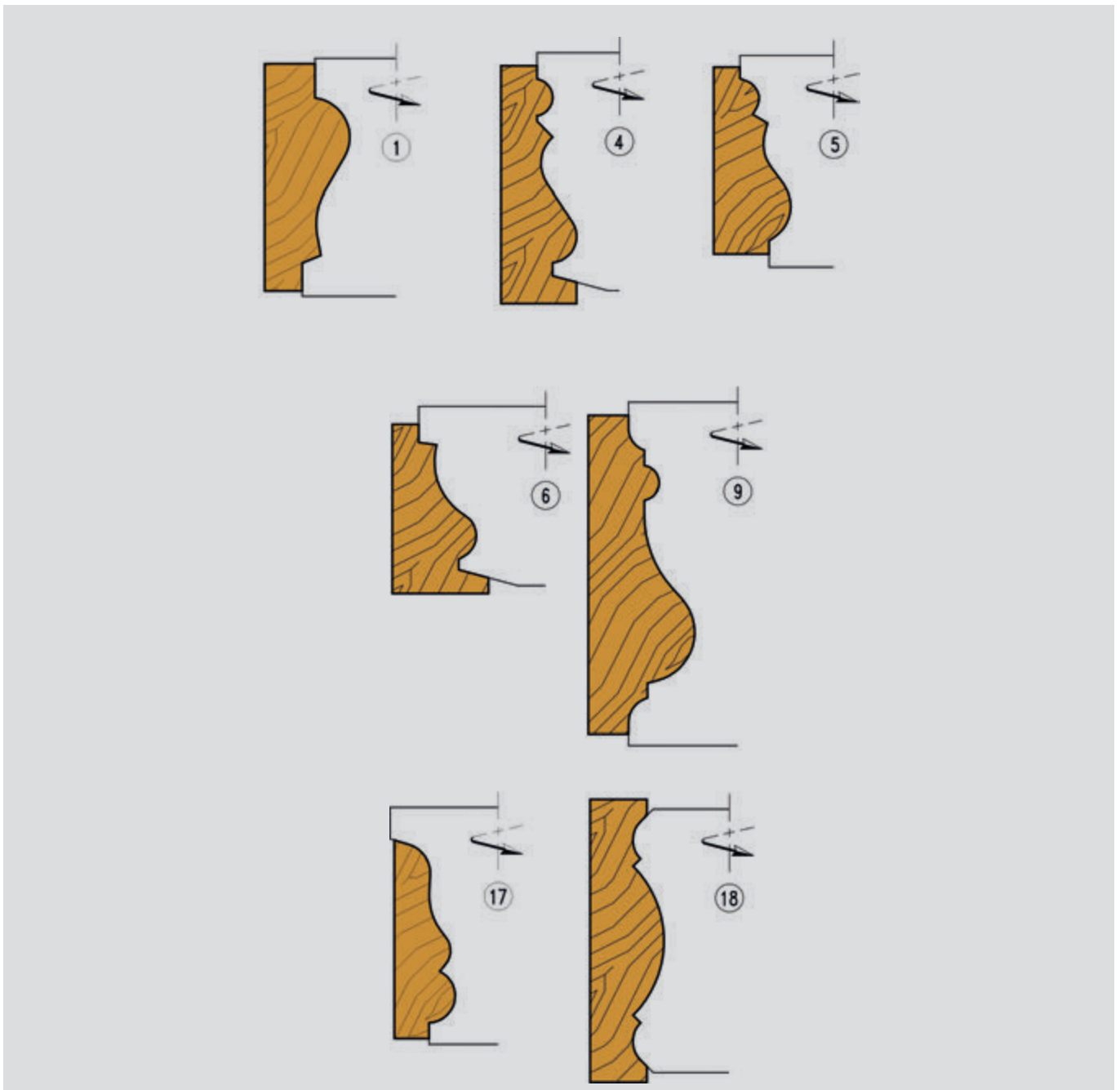
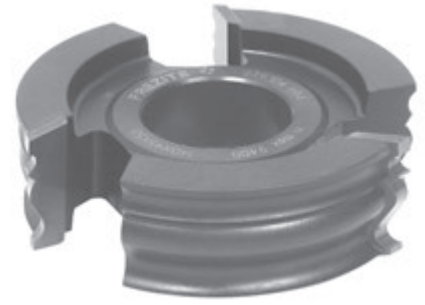

Profile cutterblock
Fraise-Profil

Nr	D	B	d	Z	n min.-max.	Ref.
1	170	38	30/50	3	4500-7800	234.101
2	150	32	30/50	3	5200-8900	234.102
3	160	32	30/50	3	4800-8300	234.103
4	180	70	30/50	3	4300-7400	234.110

MAN HW

234

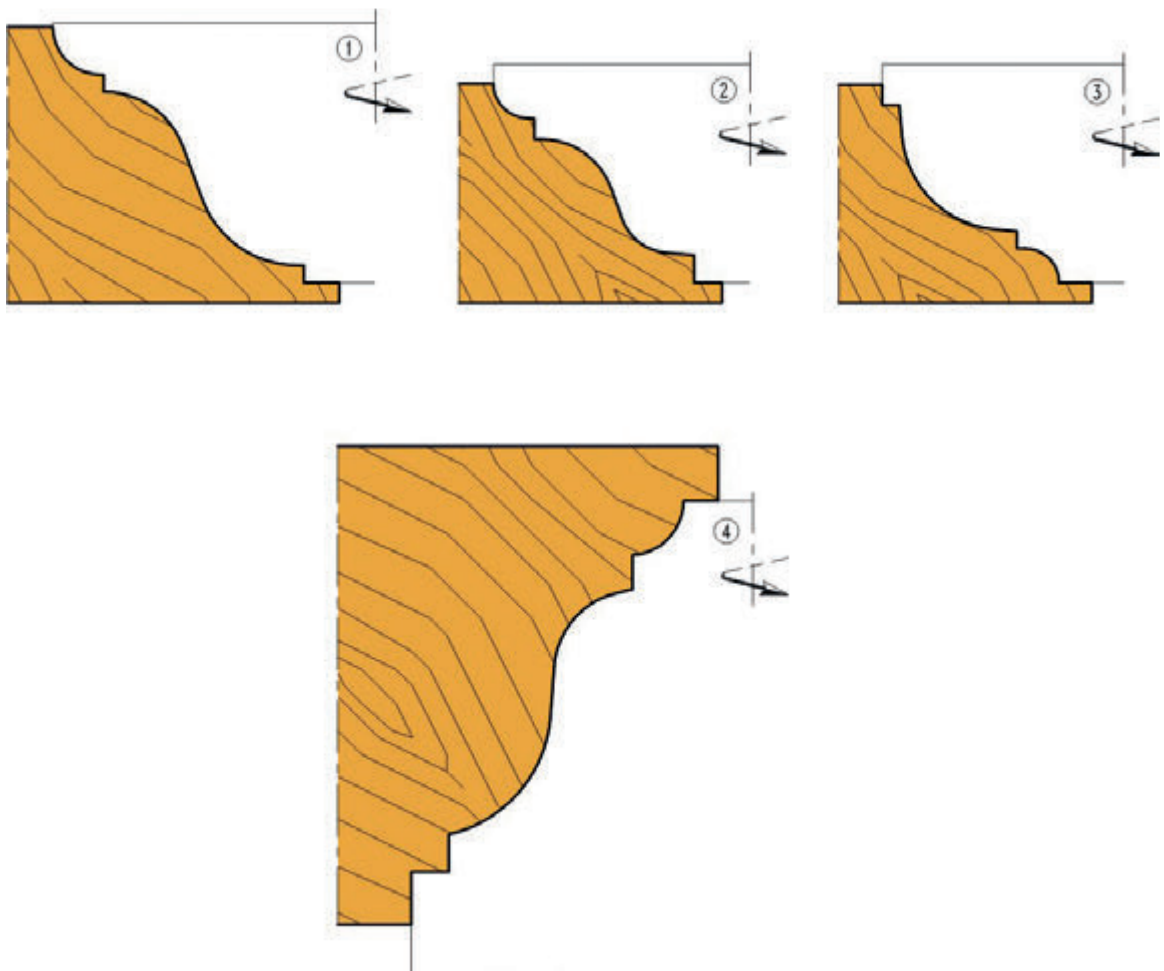

Handrail profile cutterblock
Fraise pour main courante

Nr	D	B	d	Z	n min.-max.	Ref.
1	150	40	30/50	3	5200-8900	206.101
2		70	30/50	3	5200-8900	206.102
3		55	30/50	3	5200-8900	206.105
4	160	75	30/50	3	4800-8300	206.104

MAN HW

206

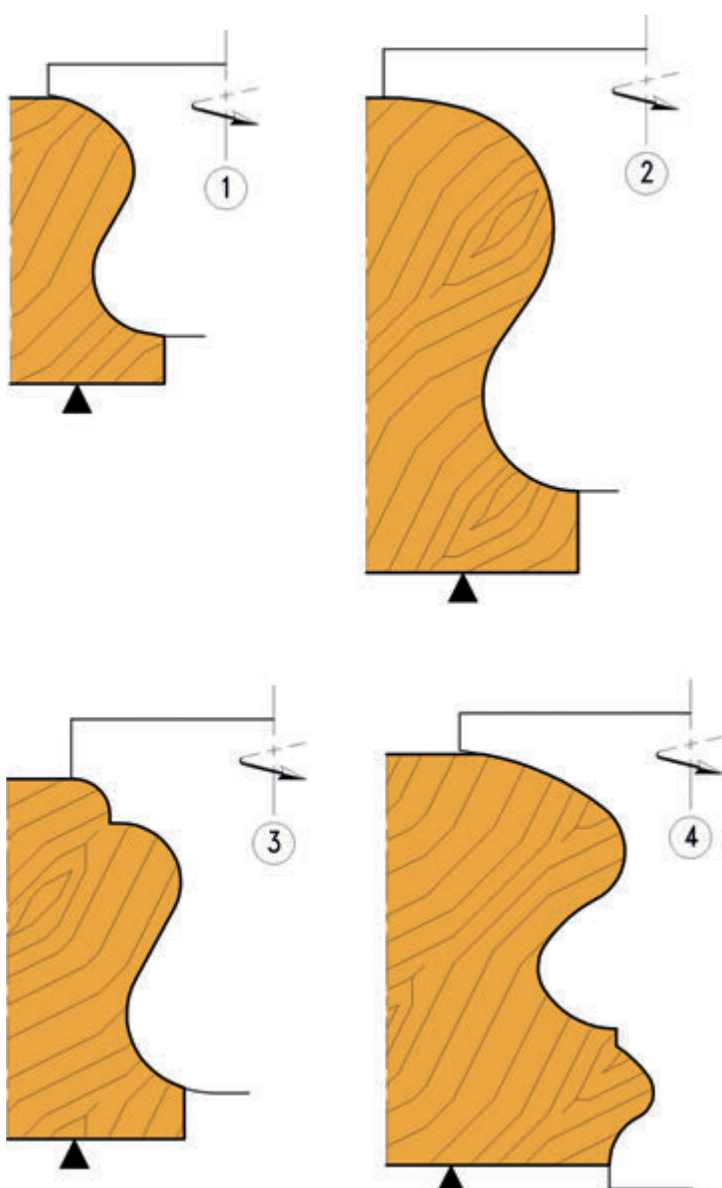

FRE

ZITE



FREZITE - Ferramentas de Corte, S.A.

Head Office / Siège social : Rua do Vau, 173, Apartado 134, 4786-909 Trofa, PORTUGAL
Tel.: +351 252 400 360 | Fax: +351 252 417 254 | e-mail: info@frezite.com

Find your local partner at / Trouvez votre partenaire de distribution à:

FREZITE Group