

2

Groovers, rebate, planing cutterblocks and cutterheads Fraises et porte-outils droit

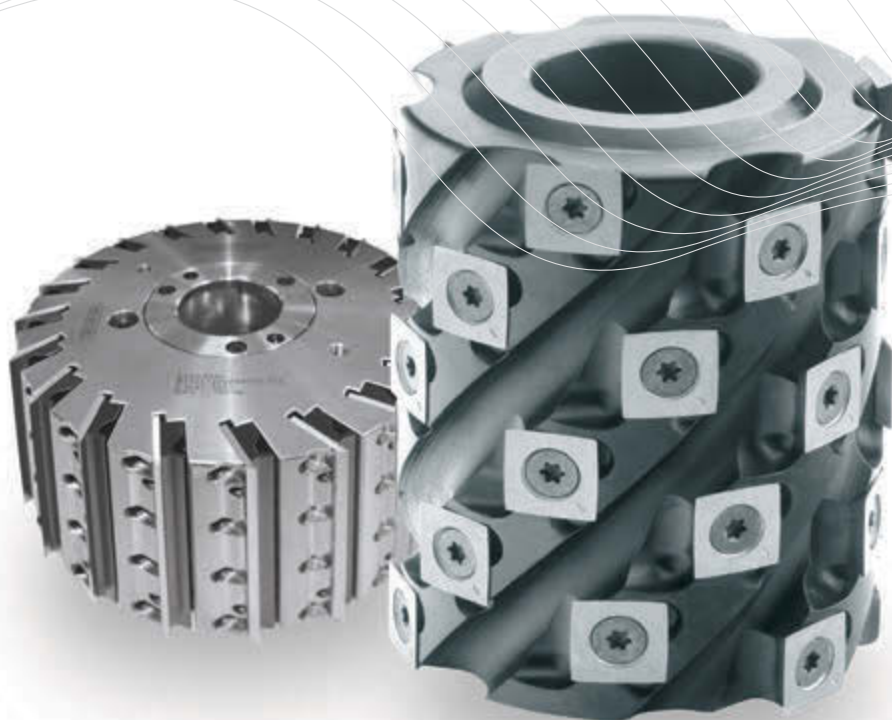

| | |
|------------------------------------------------------------|-----------|
| Grooving cutter and cutterhead | |
| Porte-outils et fraise à rainer | 2.3-2.6 |
| Grooving cutter for biscuit joiners | |
| Fraise à rainer entaillage lamelle bois | 2.6-2.8 |
| Groovingbed cutterhead | |
| Porte-outils de prédégauchissage | 2.8 |
| Adjustable thickness grooving cutter and cutterhead | |
| Porte-outils et fraise à rainer réglable | 2.9-2.16 |
| Jointing and planing cutterhead | |
| Porte-outils à feuillure | 2.17-2.19 |
| Jointing cutter and cutterhead | |
| Porte-outils et fraise à calibrer | 2.20-2.22 |
| Cutterhead for guide | |
| Porte-outils pour guide | 2.22 |
| Planing cutterblock and cutterhead | |
| Porte-outils et fraise à raboter | 2.23-2.31 |
| Cutterhead for tenoning machine | |
| Porte-outils pour tenonneuse à tenons ronds..... | 2.32 |
| Cutterhead and cutter for edge banding machine | |
| Porte-outils et fraise pour plaqueuses de chants | 2.33-2.42 |

Grooving cutterhead Porte-outil à rainer

| D | B | d | Z | V | T _{max.} | n _{min.-max.} | Ref. |
|-----|---|-------|---|---|-------------------|------------------------|---------|
| 120 | 4 | 20/30 | 4 | 4 | 27 | 6400-11100 | 551.091 |
| | 5 | 20/30 | 4 | 4 | 27 | 6400-11100 | 551.092 |
| | 6 | 20/30 | 4 | 4 | 27 | 6400-11100 | 551.093 |
| 140 | 4 | 30/50 | 4 | 4 | 32 | 5500-9500 | 551.101 |
| | 5 | 30/50 | 4 | 4 | 32 | 5500-9500 | 551.102 |
| | 6 | 30/50 | 4 | 4 | 32 | 5500-9500 | 551.103 |

MAN HW

551



Spare parts - Pièces de rechange

| | B | Dim. | Ref. |
|-------------------------------|-------|------------|---------|
| Knife - <i>Plaque</i> | 4 | 18x18x1,95 | 766.101 |
| | 5 | 18x18x2,45 | 766.102 |
| | 6 | 18x18x2,95 | 766.103 |
| Nut - <i>Écrou</i> | 4 | 11,9x1,7 | 709.129 |
| | 5/6 | 11,9x2,2 | 709.127 |
| Spur - <i>Araseurs</i> | 4/5/6 | 14x14x1,2 | 750.113 |
| Nut - <i>Écrou</i> | 4/5/6 | 9,9x1,6 | 709.128 |
| Screw - <i>Vis</i> | 4 | M4x3,2 | 705.313 |
| | 5/6 | M4x4,2 | 705.314 |
| Torx wrench - <i>Clé Torx</i> | | T9 | 706.301 |

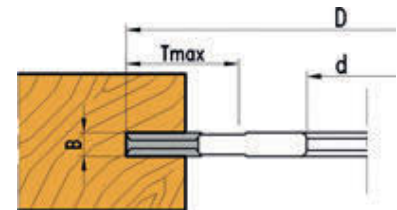

2

Grooving cutterhead Porte-outil à rainer

| D | B | d | Z | V | T _{max.} | n _{min.-max.} | Ref. |
|-----|----|-------|---|---|-------------------|------------------------|---------|
| 140 | 8 | 30/50 | 4 | 4 | 32 | 5500-9500 | 518.101 |
| | 10 | 30/50 | 4 | 4 | 32 | 5500-9500 | 518.102 |
| | 12 | 30/50 | 4 | 4 | 32 | 5500-9500 | 518.103 |
| | 15 | 30/50 | 4 | 4 | 32 | 5500-9500 | 518.104 |

MAN HW

518



Spare parts - Pièces de rechange

| | B | Dim. | Ref. |
|---------------------------------------------|-------|-------------|------------|
| Knife - <i>Plaque</i> | 8 | 7,5x12x1,5 | 750.097 |
| | 10 | 9,6x12x1,5 | 750.098 |
| | 12 | 11,6x12x1,5 | 750.099 |
| | 15 | 14,6x12x1,5 | 750.201 |
| Clamping wedge - <i>Cale</i> | 8 | | 707.002.07 |
| | 10 | | 707.002.08 |
| | 12 | | 707.002.10 |
| | 15 | | 707.002.13 |
| Screw - <i>Vis</i> | 8 | M5x16 | 705.582 |
| | 10 | M6x16 | 705.535 |
| | 12/15 | M8x16 | 705.542 |
| Spur - <i>Araseurs</i> | | 14x14x2 | 750.111 |
| Torx screw - <i>Vis Torx</i> | | M5x6 | 705.425 |
| Torx wrench - <i>Clé Torx</i> | | T15 | 706.304 |
| T Wrench- <i>Clé en T</i> | | SW2,5 | 706.102 |
| | | SW3 | 706.103 |
| | | SW4 | 706.104 |
| Adjusting gauge - <i>Calibre de réglage</i> | | 0,3/0,8 | 717.309 |

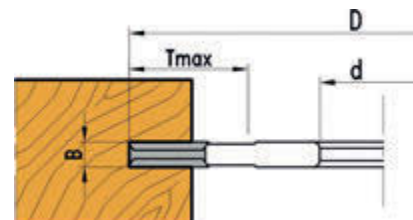

Grooving cutter
Fraise à rainier

| D | B | d | Z | T _{max.} | n _{min.-max.} | Ref. |
|-----|----|-------|---|-------------------|------------------------|---------|
| 140 | 4 | 30/50 | 4 | 32 | 5500 - 9500 | 004.351 |
| | 5 | 30/50 | 4 | 32 | 5500 - 9500 | 004.352 |
| | 6 | 30/50 | 4 | 32 | 5500 - 9500 | 004.353 |
| | 7 | 30/50 | 4 | 32 | 5500 - 9500 | 004.354 |
| | 8 | 30/50 | 4 | 32 | 5500 - 9500 | 004.355 |
| | 10 | 30/50 | 4 | 32 | 5500 - 9500 | 004.356 |
| | 12 | 30/50 | 4 | 32 | 5500 - 9500 | 004.357 |
| | 14 | 30/50 | 4 | 32 | 5500 - 9500 | 004.358 |
| | 16 | 30/50 | 4 | 32 | 5500 - 9500 | 004.359 |
| | 20 | 30/50 | 4 | 32 | 5500 - 9500 | 004.361 |

MAN HW

004

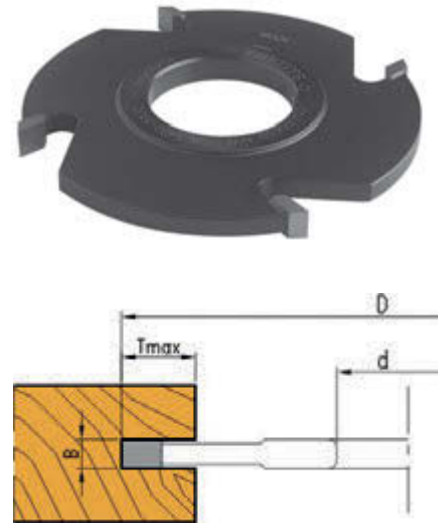

Grooving cutter
Fraise à rainier

| D | B | d | Z | T _{max.} | n _{min.-max.} | Ref. |
|-----|----|-------|---|-------------------|------------------------|---------|
| 140 | 4 | 30/50 | 6 | 32 | 5500-9500 | 006.100 |
| | 5 | 30/50 | 6 | 32 | 5500-9500 | 006.101 |
| | 6 | 30/50 | 6 | 32 | 5500-9500 | 006.102 |
| | 8 | 30/50 | 6 | 32 | 5500-9500 | 006.104 |
| | 10 | 30/50 | 6 | 32 | 5500-9500 | 006.105 |
| | 12 | 30/50 | 6 | 32 | 5500-9500 | 006.106 |
| | 14 | 30/50 | 6 | 32 | 5500-9500 | 006.107 |
| | 16 | 30/50 | 6 | 32 | 5500-9500 | 006.108 |
| | 20 | 30/50 | 6 | 32 | 5500-9500 | 006.110 |

MAN HW

006

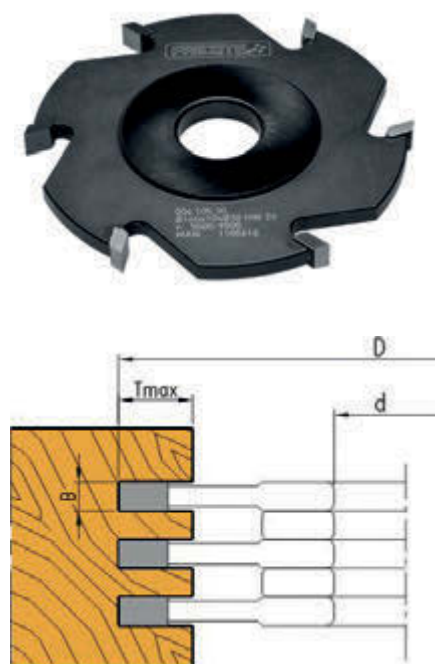

Grooving and rebating diamond cutter
Fraises à rainier et dresser, DP



| D | B | d | Z | n _{max.} | Ref. |
|--------|---|----|----|-------------------|-----------------|
| DP=5mm | | | | | |
| 120 | 4 | 30 | 8 | 12000 | A805.120.004.30 |
| | 5 | 30 | 8 | 12000 | A805.120.005.30 |
| | 6 | 30 | 8 | 12000 | A805.120.006.30 |
| 150 | 4 | 30 | 12 | 12000 | A805.150.004.30 |
| | 5 | 30 | 12 | 12000 | A805.150.005.30 |
| | 6 | 30 | 12 | 12000 | A805.150.006.30 |

MEC DP

A805



Grooving and rebating diamond cutter
Fraises à rainier et dresser, DP



| D | B | d | Z | n _{max.} | Ref.LH | Ref.RH |
|--------|---|----|----|-------------------|-----------------|-----------------|
| DP=5mm | | | | | | |
| 120 | 5 | 30 | 8 | 10000 | A817.120.005.30 | A817.120.105.30 |
| | 6 | 30 | 8 | 10000 | A817.120.006.30 | A817.120.106.30 |
| 150 | 5 | 30 | 12 | 10000 | A817.150.005.30 | A817.150.105.30 |
| | 6 | 30 | 12 | 10000 | A817.150.006.30 | A817.150.106.30 |

MEC DP

A817

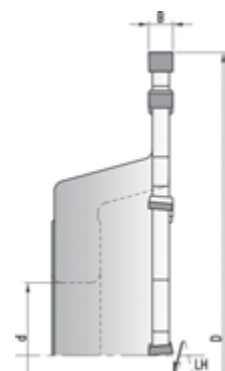

Spur type grooving cutter Fraise à rainier avec araseurs

| D | B | d | Z | V | T _{max.} | n _{min.-max.} | Ref. |
|-----|----|-------|---|---|-------------------|------------------------|---------|
| 140 | 4 | 30/50 | 4 | 4 | 32 | 5500-9500 | 016.301 |
| | 5 | 30/50 | 4 | 4 | 32 | 5500-9500 | 016.302 |
| | 6 | 30/50 | 4 | 4 | 32 | 5500-9500 | 016.303 |
| | 8 | 30/50 | 4 | 4 | 32 | 5500-9500 | 016.304 |
| | 10 | 30/50 | 4 | 4 | 32 | 5500-9500 | 016.305 |
| | 12 | 30/50 | 4 | 4 | 32 | 5500-9500 | 016.306 |
| | 16 | 30/50 | 4 | 4 | 32 | 5500-9500 | 016.307 |
| 160 | 4 | 30/50 | 4 | 4 | 42 | 4800-8300 | 016.701 |
| | 6 | 30/50 | 4 | 4 | 42 | 4800-8300 | 016.703 |
| | 8 | 30/50 | 4 | 4 | 42 | 4800-8300 | 016.704 |
| | 10 | 30/50 | 4 | 4 | 42 | 4800-8300 | 016.705 |
| | 12 | 30/50 | 4 | 4 | 42 | 4800-8300 | 016.706 |
| | 16 | 30/50 | 4 | 4 | 42 | 4800-8300 | 016.707 |
| | 20 | 30/50 | 4 | 4 | 42 | 4800-8300 | 016.709 |

MAN HW

016

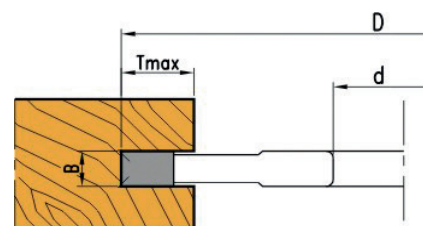

Grooving cutter for biscuit joiners Fraise à rainier entaillage lamelle bois

| D | B | d | Z | V | NL | n _{min.-max.} | Ref. |
|-----|------|----|---|---|----------|------------------------|---------|
| 100 | 3,97 | 22 | 4 | 4 | 4/4.5/36 | 7800-13300 | 580.101 |

MAN HW

580

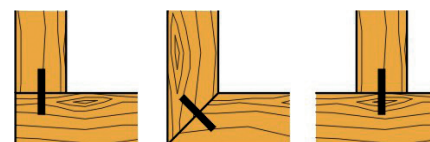

Spare parts - Pièces de rechange

| | Dim. | Ref. |
|------------------------|------------|---------|
| Knife - Plaque | 18x18x1,95 | 766.101 |
| Nut - Écrou | 11,9x1,7 | 709.129 |
| Spur - Araseurs | 14x14x1,2 | 750.113 |
| Nut - Écrou | 9,9x1,6 | 709.128 |
| Screw - Vis | M4x3,2 | 705.313 |
| Torx wrench - Clé Torx | T9 | 706.301 |

Grooving cutter for biscuit joiners
Fraise à rainer pour entaillage lamelle bois

| D | B | b | d | Z | NL | n min.-max. | Ref. |
|-----|------|-----|----|---|----------|----------------|---------|
| 100 | 3,97 | 2,8 | 22 | 6 | 4/4.5/36 | 7800-13300 | 018.201 |
| | 3,97 | 2,8 | 22 | 8 | 4/4.5/36 | 7800-13300 | 018.202 |

MAN HW

018

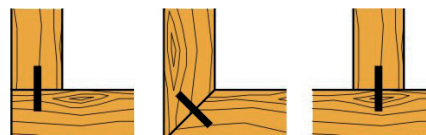

Diamond grooving cutter
Fraise à rainier DP



| D | B | d | Z | NL | n min-max | Ref. |
|-------|---|----|---|----------|--------------|-----------------|
| 100,4 | 7 | 22 | 3 | 4/4,5/36 | 7800-13300 | A828.100.107.22 |

MAN DP

A828

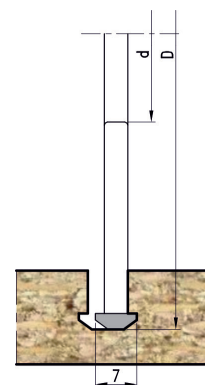

Grooving cutter for minispot Fraise à rainier minispot

| D | B | d | Z | NL | n min.-max. | Ref. |
|-----|----|----|---|----------|----------------|---------|
| 100 | 8 | 22 | 4 | 4/4.3/36 | 7800-13300 | 237.101 |
| | 15 | 22 | 4 | 2/4,3/36 | 7800-13300 | 237.104 |

MAN HW

237



Groovingbed cutterhead Porte-outils de prédégauçissage

| D | B | d | Z | V | n max. | Ref. |
|-----|----|----|---|---|-----------|---------|
| 125 | 9 | 40 | 2 | 2 | 11500 | 522.103 |
| | 10 | 40 | 2 | 2 | 11500 | 522.102 |
| | 17 | 40 | 2 | 2 | 11500 | 522.104 |
| | 20 | 40 | 2 | 2 | 11500 | 522.101 |

MEC HW

522



Spare parts - Pièces de rechange

| | B | Dim. | Ref. |
|--------------------------------------|-------|------------|------------|
| Knife - Plaquette | 9 | 8,6x12x1,5 | 750.095 |
| | 10 | 9,6x12x1,5 | 750.098 |
| | 17 | 17x12x1,5 | 750.115 |
| | 20 | 20x12x1,5 | 750.102 |
| Clamping wedge - Cale | 9/10 | | 707.002.08 |
| | 17 | | 707.002.15 |
| | 20 | | 707.002.18 |
| Screw - Vis | 9/10 | M6x12 | 705.533 |
| | 17/20 | M8x16 | 705.542 |
| Spur - Araseurs | | 14x14x2 | 750.111 |
| Torx screw - Vis Torx | | M5x6 | 705.425 |
| Torx wrench - Clé Torx | | T15 | 706.304 |
| T Wrench - Clé en T | | SW3 | 706.103 |
| | | SW4 | 706.104 |
| Spacers - Bagues | 9 | | 703.411 |
| | 10 | | 703.412 |
| | 12 | | 703.413 |
| Adjusting gauge - Calibre de réglage | | 0,3/0,8 | 717.309 |

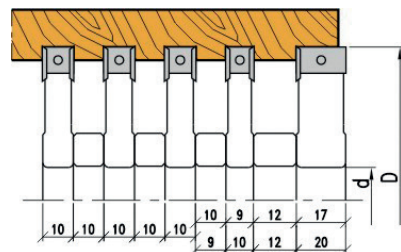

Adjustable thickness grooving cutterhead Porte-outils à rainier extensible

| D | B | d | Z | V | T _{max.} | n _{min.-max.} | Ref. |
|-----|-------|-------|---|---|-------------------|------------------------|---------|
| 160 | 4-7,5 | 30/50 | 8 | 4 | 32 | 4800-8300 | 538.101 |
| | 4-15 | 30/50 | 8 | 4 | 32 | 4800-8300 | 538.151 |
| 180 | 4-7,5 | 30/50 | 8 | 4 | 38 | 4300-7400 | 538.501 |
| | 4-15 | 30/50 | 8 | 4 | 38 | 4300-7400 | 538.551 |

Spare parts - Pièces de rechange

| | B | Dim. | Ref. | |
|------------------------------------|---|------------|------------|------------|
| Knife - <i>Plaque</i> | | 7,5 (4-15) | 7,5x12x1,5 | 750.097 |
| Clamping wedge - <i>Cale</i> | | 7,5 (4-15) | | 707.002.07 |
| Screw - <i>Vis</i> | | 7,5 (4-15) | M5x12 | 705.523 |
| Knife - <i>Plaque</i> | | 4-7,5 | 18x18x1,95 | 766.101 |
| Nut - <i>Écrou</i> | | 4-7,5 | 11,9x1,7 | 709.129 |
| Spur - <i>Araseurs</i> | | 4-7,5 | 14x14x1,2 | 750.113 |
| Nut - <i>Écrou</i> | | 4-7,5 | 9,9x1,6 | 709.128 |
| Screw - <i>Vis</i> | | 4-7,5 | M4x3,2 | 705.313 |
| T Wrench - <i>Clé en T</i> | | | SW2,5 | 706.102 |
| Torx wrench - <i>Clé Torx</i> | | | T9 | 706.301 |
| Spacers set - <i>Jeu de bagues</i> | | 4-7,5 | | 703.032 |

MAN HW

538

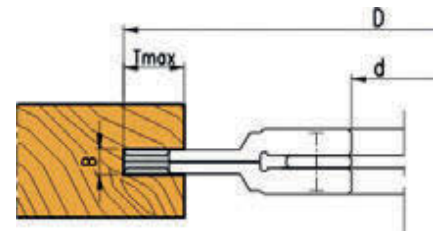

B = 4-7,5: with 2 piece - avec 2 fraises
B = 4-15 : with 3 piece - avec 3 fraises

2

Adjustable thickness grooving cutterhead Porte-outils à rainier réglable

| D | B | d | Z | V | T _{max.} | n _{min.-max.} | Ref. |
|-----|---------|-------|---|---|-------------------|------------------------|---------|
| 160 | 8-15 | 30/50 | 4 | 4 | 32 | 4800-8300 | 546.101 |
| | 12,6-24 | 30/50 | 4 | 4 | 32 | 4800-8300 | 546.151 |
| 180 | 8-15 | 30/50 | 4 | 4 | 38 | 4300-7400 | 546.501 |
| | 12,6-24 | 30/50 | 4 | 4 | 38 | 4300-7400 | 546.551 |

Spare parts - Pièces de rechange

| | B | Dim. | Ref. |
|---------------------------------------------|---------|------------|------------|
| Knife - <i>Plaquette</i> | 8-15 | 7,5x12x1,5 | 750.097 |
| | 12,6-24 | 12x12x1,5 | 754.102 |
| Clamping wedge - <i>Cale</i> | 8-15 | | 707.002.06 |
| | 12,6-24 | | 707.002.10 |
| Screw - <i>Vis</i> | 8-15 | M5x16 | 705.582 |
| | 12,6-24 | M8x16 | 705.542 |
| Spur - <i>Araseurs</i> | | 14x14x2 | 750.111 |
| Torx screw - <i>Vis Torx</i> | | M5x6 | 705.425 |
| Torx wrench - <i>Clé Torx</i> | | T15 | 706.304 |
| T Wrench - <i>Clé en T</i> | | W2,5 | 706.102 |
| | | SW4 | 706.104 |
| Spacer set - <i>Jeu de bagues</i> | 8-15 | | 703.039 |
| | 12,6-24 | | 703.040 |
| Adjusting gauge - <i>Calibre de réglage</i> | | 0,3/0,8 | 717.309 |

MAN HW

546

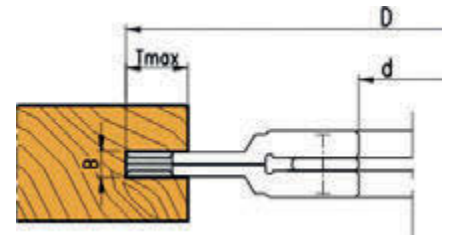

Adjustable thickness grooving cutterhead Porte-outils à rainier réglable

| D | B | d | Z | V | T _{max.} | n _{min.-max.} | Ref. |
|-----|-------|-------|---|---|-------------------|------------------------|---------|
| 180 | 4-7,5 | 30/50 | 8 | 4 | 32 | 4300-7400 | 537.101 |

Spare parts - Pièces de rechange

| | Dim. | Ref. |
|-------------------------------|------------|---------|
| Knife - <i>Plaquette</i> | 18x18x1,95 | 766.101 |
| Nut - <i>Écrou</i> | 11,9x1,7 | 709.129 |
| Spur - <i>Araseurs</i> | 14x14x1,2 | 750.113 |
| Nut - <i>Écrou</i> | 9,9x1,6 | 709.128 |
| Screw - <i>Vis</i> | M4x3,2 | 705.313 |
| Torx wrench - <i>Clé Torx</i> | T9 | 706.301 |

MAN HW

537

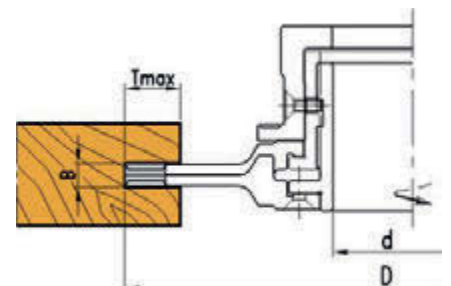

Adjustable thickness grooving cutterhead Porte-outils à rainier réglable

| D | B | d | Z | V | T _{max.} | n _{min.-max.} | Ref. |
|-----|---------|-------|---|---|-------------------|------------------------|---------|
| 180 | 8-15 | 30/50 | 4 | 4 | 32 | 4300-7400 | 548.101 |
| | 12,6-24 | 30/50 | 4 | 4 | 32 | 4300-7400 | 548.102 |

Spare parts - Pièces de rechange

| | B | Dim. | Ref. |
|---------------------------------------------|---------|------------|------------|
| Knife - <i>Plaquette</i> | 8-15 | 7,5x12x1,5 | 750.097 |
| | 12,6-24 | 12x12x1,5 | 754.102 |
| Clamping wedge - <i>Cale</i> | 8-15 | | 707.002.06 |
| | 12,6-24 | | 707.002.10 |
| Screw - <i>Vis</i> | 8-15 | M5x16 | 705.582 |
| | 12,6-24 | M8x16 | 705.542 |
| Spur - <i>Araseurs</i> | | 14x14x2 | 750.111 |
| Torx screw - <i>Vis Torx</i> | | M5x6 | 705.425 |
| Torx wrench - <i>Clé Torx</i> | | T15 | 706.304 |
| T Wrench - <i>Clé en T</i> | | W2,5 (M5) | 706.102 |
| | | SW4 (M8) | 706.104 |
| Adjusting gauge - <i>Calibre de réglage</i> | | 0,3/0,8 | 717.309 |

MAN HW

548

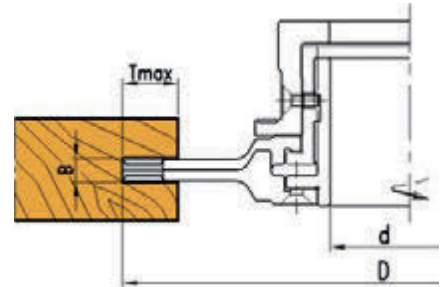

2

Adjustable thickness grooving cutter with spurs Fraise à rainier réglable avec araseurs

| D | B | d | Z | V | T _{max.} | n _{min.-max.} | Ref. |
|-----|--------|-------|---|---|-------------------|------------------------|---------|
| 150 | 4-7,5 | 30/50 | 4 | 4 | 27 | 5200-8900 | 041.301 |
| | 7-13,5 | 30/50 | 4 | 4 | 27 | 5200-8900 | 041.302 |

MAN HW

041

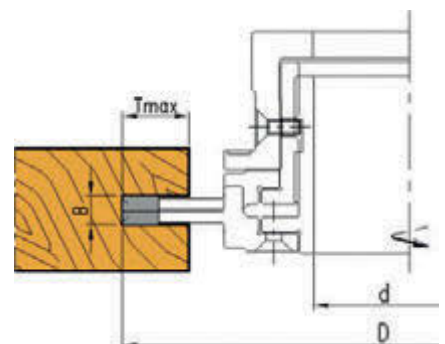

Adjustable thickness grooving cutter
Fraise à rainier réglable

| D | B | d | Z | T _{max.} | n _{min.-max.} | Ref. |
|-----|---------|----|-------|-------------------|------------------------|---------|
| 120 | 1,8-3,4 | 30 | 6+6 | 12 | 6400-11100 | 044.201 |
| | 2,2-4,0 | 30 | 6+6 | 15 | 6400-11100 | 044.202 |
| 140 | 2,2-4,0 | 50 | 6+6 | 15 | 5500-9500 | 044.301 |
| 220 | 3,5-6,5 | 30 | 20+20 | 17 | 3500-6000 | 044.401 |

MAN HW

044

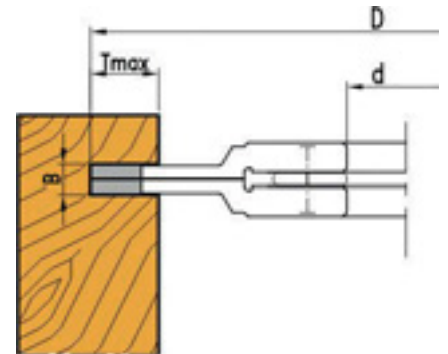

Adjustable thickness grooving cutter with spurs Fraise à rainier réglable avec araseurs

| D | B | d | Z | V | T _{max.} | n _{min.-max.} | Ref. |
|-----|---------|-------|---|---|-------------------|------------------------|-----------|
| 120 | 3,5-6,5 | 0/50 | 4 | 4 | 16 | 400-11100 | 030.100 |
| | 4-7,5 | 30/50 | 4 | 4 | 16 | 400-11100 | 030.101 ■ |
| | 5-9,5 | 30/50 | 4 | 4 | 16 | 400-11100 | 030.102 |
| | 7-13,5 | 30/50 | 4 | 4 | 16 | 400-11100 | 030.103 ■ |
| 140 | 10-19,5 | 30/50 | 4 | 4 | 16 | 400-11100 | 030.104 ■ |
| | 4-7,5 | 30/50 | 4 | 4 | 22 | 5500-9500 | 030.301 |
| | 5-9,5 | 30/50 | 4 | 4 | 22 | 5500-9500 | 030.302 |
| | 7-13,5 | 30/50 | 4 | 4 | 22 | 5500-9500 | 030.303 |
| 150 | 10-19,5 | 30/50 | 4 | 4 | 22 | 5500-9500 | 030.304 |
| | 15-29,5 | 30/50 | 4 | 4 | 22 | 5500-9500 | 030.305 |
| | 20-39,5 | 30/50 | 4 | 4 | 22 | 5500-9500 | 030.306 |
| | 30-59,5 | 30/50 | 4 | 4 | 22 | 5500-9500 | 030.307 |
| 160 | 4-7,5 | 30/50 | 4 | 4 | 27 | 5200-8900 | 030.501 ■ |
| | 5-9,5 | 30/50 | 4 | 4 | 27 | 5200-8900 | 030.502 ■ |
| | 7-13,5 | 30/50 | 4 | 4 | 27 | 5200-8900 | 030.503 ■ |
| 160 | 4-7,5 | 30/50 | 4 | 4 | 32 | 4800-8300 | 030.701 |
| | 5-9,5 | 30/50 | 4 | 4 | 32 | 4800-8300 | 030.702 |
| | 7-13,5 | 30/50 | 4 | 4 | 32 | 4800-8300 | 030.703 |
| | 10-19,5 | 30/50 | 4 | 4 | 32 | 4800-8300 | 030.704 |

■ While quantities last - Jusqu'à épuisement du stock

MAN HW

030

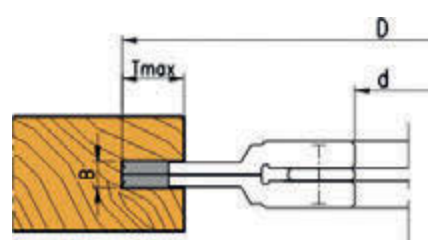

Spacer set - Jeu de bagues

| B | d | Ref. |
|---------|-------|---------|
| 3,5-6,5 | 30/50 | 703.031 |
| 4-7,5 | 30/50 | 703.032 |
| 5-9,5 | 30/50 | 703.033 |
| 7-13,5 | 30/50 | 703.034 |
| 10-19,5 | 30/50 | 703.035 |
| 20-39,5 | 30/50 | 703.037 |
| 30-59,5 | 30/50 | 703.038 |

Adjustable thickness grooving cutter with spurs
Fraise à rainier réglable avec araseurs

| D | B | d | Z | V | T _{max.} | n _{min.-max.} | Ref. |
|-----|---------|-------|---|---|-------------------|------------------------|---------|
| 200 | 5 - 9,5 | 30/50 | 4 | 4 | 45 | 3900-6600 | 011.101 |
| | 10-19,5 | 30/50 | 4 | 4 | 45 | 3900-6600 | 011.103 |
| 250 | 7-13,5 | 30/50 | 4 | 4 | 70 | 3100-5300 | 011.301 |
| | 10-19,5 | 30/50 | 4 | 4 | 70 | 3100-5300 | 011.302 |
| | 15-29,5 | 30/50 | 4 | 4 | 70 | 3100-5300 | 011.303 |

Spacer set - Jeu de bagues

| B | d | Ref. |
|---------|-------|---------|
| 5-9,5 | 30/50 | 703.033 |
| 7-13,5 | 30/50 | 703.034 |
| 10-19,5 | 30/50 | 703.035 |
| 15-29,5 | 30/50 | 703.036 |

MAN HW

011

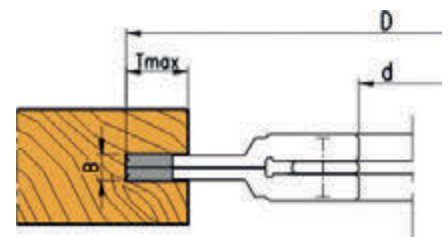

Adjustable thickness grooving cutter with spurs
Fraise à rainier réglable avec araseurs

| D | B | d | Z | V | T _{max.} | n _{min.-max.} | Ref. |
|-----|---------|----|---|---|-------------------|------------------------|---------|
| 250 | 7-13,5 | 30 | 8 | 8 | 40 | 3100-5300 | 019.101 |
| | 10-19,5 | 30 | 8 | 8 | 40 | 3100-5300 | 019.102 |
| | 15-29,5 | 30 | 8 | 8 | 40 | 3100-5300 | 019.103 |

Spacer set - Jeu de bagues

| B | d | Ref. |
|---------|----|---------|
| 7-13,5 | 30 | 703.034 |
| 10-19,5 | 30 | 703.035 |
| 15-29,5 | 30 | 703.036 |

MAN HW

019

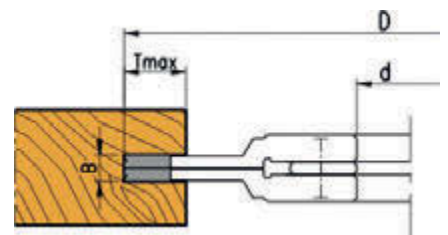

Adjustable thickness grooving diamond cutter
Fraise à rainer réglable, DP



| D | B | d | Z | T _{max.} | n _{min.-max.} | Ref. |
|---------------|---------|----|-----|-------------------|------------------------|-----------------|
| DP=5mm | | | | | | |
| 100 | 3,5-6,5 | 30 | 4+4 | 10 | 5200-8900 | A808.100.100.30 |
| 150 | 4-7,5 | 30 | 6+6 | 15 | 5200-8900 | A808.150.100.30 |
| 200 | 7-13,5 | 30 | 6+6 | 20 | 3900-6600 | A808.200.101.30 |

Spacer set - Jeu de bagues

| B | d | Ref. |
|---------|-------|---------|
| 3,5-6,5 | 30/50 | 703.031 |
| 4-7,5 | 30/50 | 703.032 |
| 7-13,5 | 30/50 | 703.034 |

MAN DP

A808

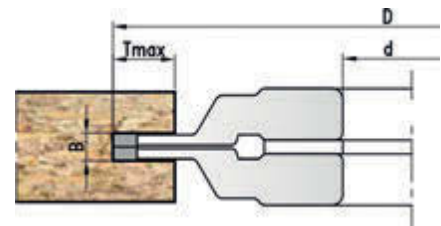
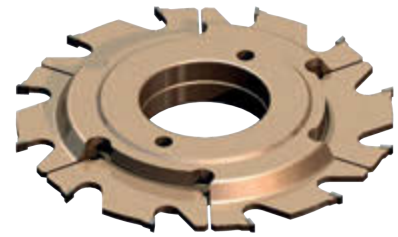

Adjustable thickness grooving diamond cutter
Fraise à rainer réglable, DP



| D | B | d | Z | n _{max.} | Ref.LH | Ref.RH |
|---------------|--------|----|-----|-------------------|-----------------|-----------------|
| DP=5mm | | | | | | |
| 120 | 4-7,5 | 30 | 8+8 | 10000 | A818.120.004.30 | A818.120.104.30 |
| | 7-13,5 | 30 | 8+8 | 10000 | A818.120.007.30 | A818.120.107.30 |
| 160 | 4-7,5 | 30 | 8+8 | 8500 | A818.160.004.30 | A818.160.104.30 |
| | 7-13,5 | 30 | 8+8 | 8500 | A818.160.007.30 | A818.160.107.30 |

Spacer set - Jeu de bagues

| B | d | Ref. |
|--------|----|---------|
| 4-7,5 | 30 | 703.903 |
| 7-13,5 | 30 | 703.919 |

MAN DP

A818

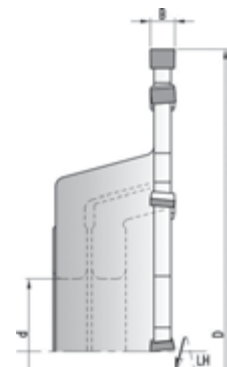

Adjustable grooving / rebating cutterhead Porte-outils feuillure

| D | B | d | Z | V | n ⁿ min.-max. | Ref. |
|-----|--------|-------|---|---|-----------------------------|---------|
| 160 | 16-30 | 30/50 | 4 | 4 | 4800-8300 | 530.100 |
| | 21-40 | 30/50 | 4 | 4 | 4800-8300 | 530.101 |
| | 31-60 | 30/50 | 4 | 4 | 4800-8300 | 530.102 |
| | 51-100 | 30/50 | 4 | 4 | 4800-8300 | 530.103 |

Spare parts - Pièces de rechange

| | B | Dim. | Ref. |
|---------------------------------------------|--------|-----------|------------|
| Knife - <i>Plaque</i> | 16-30 | 15x12x1,5 | 750.101 |
| | 21-40 | 20x12x1,5 | 750.102 |
| Clamping wedge - <i>Cale</i> | 31-60 | 30x12x1,5 | 750.104 |
| | 51-100 | 50x12x1,5 | 750.106 |
| | 16-30 | | 707.002.13 |
| | 21-40 | | 707.002.18 |
| | 31-60 | | 707.002.28 |
| | 51-100 | | 707.002.48 |
| Screw - <i>Vis</i> | | M8x16 | 705.542 |
| T Wrench - <i>Clé en T</i> | | SW4 | 706.104 |
| Spur - <i>Araseurs</i> | | 14x14x2 | 750.111 |
| Torx screw - <i>Vis Torx</i> | | M5x6 | 705.425 |
| Torx wrench - <i>Clé Torx</i> | | T15 | 706.304 |
| Spacer set - <i>Jeu de bagues</i> | 16-30 | | 703.036 |
| | 21-40 | | 703.037 |
| | 31-60 | | 703.038 |
| | 51-100 | | 703.042 |
| Adjusting gauge - <i>Calibre de réglage</i> | | 0,3/0,8 | 717.309 |

MAN HW

530

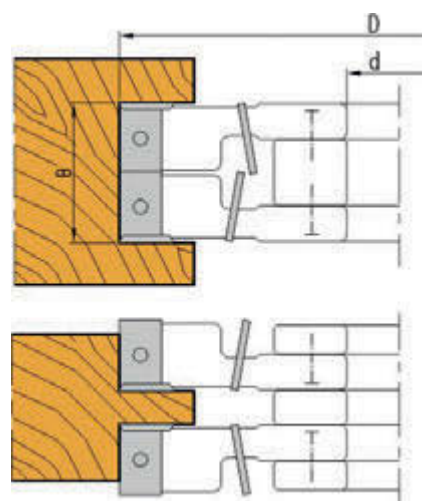

Jointing and planing cutterhead Porte-outils à raboter

| D | B | d | Z | n min.-max. | Ref. |
|-----|----|----------|---|----------------|---------|
| 80 | 50 | 45 | 4 | 9600-16000 | 505.601 |
| 100 | 30 | 30/35 | 4 | 7800-13300 | 505.101 |
| | 50 | 30/35 | 4 | 7800-13300 | 505.102 |
| 125 | 30 | 35/40/50 | 4 | 6200-10600 | 505.403 |
| | 50 | 35/40/50 | 4 | 6200-10600 | 505.404 |
| | 60 | 40/50 | 4 | 6200-10600 | 505.415 |
| | 80 | 40/50 | 4 | 6200-10600 | 505.416 |

Spare parts - Pièces de rechange

| | B | Dim. | Ref. |
|---------------------------------------------|----------|------------|------------|
| Knife - <i>Plaquette</i> | 30 | 30x12x1,5 | 750.104 |
| | 50 | 50x12x1,5 | 750.106 |
| | 60 | 60x12x1,5 | 750.107 |
| | 80 | 80x13x2,2 | 750.108 |
| Clamping wedge - <i>Cale</i> | 30 | | 707.002.28 |
| | 50 (D80) | | 707.001.48 |
| | 50 | | 707.002.48 |
| | 60 | | 707.002.58 |
| | 80 | | 707.002.78 |
| Screw - <i>Vis</i> | | M6x12(D80) | 705.533 |
| | | M8x16 | 705.542 |
| T Wrench- <i>Clé en T</i> | | SW3 | 706.103 |
| | | SW4 | 706.104 |
| Adjusting gauge - <i>Calibre de réglage</i> | | 1,0 | 717.302 |

MAN HW

505



Pin can be removed for individual use.

Goupille amovible pour permettre son utilisation individuelle.

2

Copier cutterhead Porte-outils à copier

| Nr. | D | B | d | Z | n min.-max. | Ref. |
|-----|---------|----|------|---|----------------|---------|
| 1 | 50 | | 50 | | | 709.138 |
| 2 | 62 | | 25 | | | 701.108 |
| 3 | 62 | 50 | 25 | 4 | | 531.102 |
| 4 | 40 | | 16,5 | | | 709.139 |
| | 1+2+3+4 | | | | 12400-18000 | 531.101 |

Spare parts - Pièces de rechange

| | B | Dim. | Ref. |
|------------------------------|----|-----------|------------|
| Knife - <i>Plaquette</i> | 50 | 50x12x1,5 | 750.106 |
| Clamping wedge - <i>Cale</i> | | | 707.001.48 |
| Screw - <i>Vis</i> | | M6x12 | 705.533 |
| T Wrench- <i>Clé en T</i> | | SW3 | 706.103 |

MAN HW

531

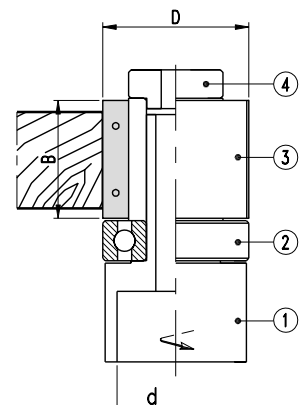

Jointing and rebating cutterhead Porte-outils à feuillure

| D | B | d | Z | V | n ⁿ min.-max. | Ref. |
|-----|----|-------|---|---|-----------------------------|---------|
| 100 | 50 | 30 | 2 | 4 | 7800-13300 | 513.106 |
| | 50 | 30 | 4 | 4 | 7800-13300 | 513.306 |
| 125 | 30 | 30/50 | 2 | 4 | 6200-10600 | 513.107 |
| | 30 | 30/50 | 4 | 4 | 6200-10600 | 513.307 |
| | 50 | 30/50 | 2 | 4 | 6200-10600 | 513.108 |
| | 50 | 30/50 | 4 | 4 | 6200-10600 | 513.308 |
| | 60 | 30/50 | 2 | 4 | 6200-10600 | 513.109 |

Spare parts - Pièces de rechange

| | B | Dim. | Ref. |
|---------------------------------------------|-----------|---------|------------|
| Knife - <i>Plaquette</i> | 30x12x1,5 | 30 | 750.104 |
| | 50x12x1,5 | 50 | 750.106 |
| | 60x12x1,5 | 60 | 750.107 |
| Clamping wedge - <i>Cale</i> | | 30 | 707.002.28 |
| | | 50 | 707.002.48 |
| | | 60 | 707.002.58 |
| Screw - <i>Vis</i> | | M8x16 | 705.542 |
| T Wrench - <i>Clé en T</i> | | SW4 | 706.104 |
| Spur - <i>Araseurs</i> | | 14x14x2 | 750.111 |
| Torx screw - <i>Vis Torx</i> | | M5x6 | 705.425 |
| Torx wrench - <i>Clé Torx</i> | | SW4 | 706.304 |
| Adjusting gauge - <i>Calibre de réglage</i> | | 1,0 | 717.302 |

MAN HW

513

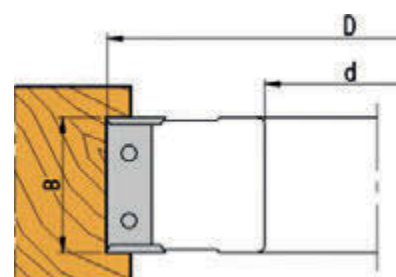

Jointing and rebating cutterhead Porte-outils à feuillure

| D | B | d | Z | V | n min.-max. | Ref. |
|-----|----|-------|---|---|----------------|---------|
| 125 | 50 | 30/50 | 4 | 4 | 6200-10600 | 536.201 |
| 140 | 50 | 30/50 | 4 | 4 | 5500-9500 | 536.401 |
| 147 | 50 | 40 | 4 | 4 | 5200-9000 | 536.410 |

Spare parts - Pièces de rechange

| | B | Dim. | Ref. |
|--------------------------------------|----|-----------|--------------------------------|
| Knife - Plaquette | 50 | 50x12x1,5 | 750.106 |
| Clamping wedge - Cale | | | RH 707.133.50 LH 707.130.50 |
| Screw - Vis | | M8x16 | 705.542 |
| T Wrench - Clé en T | | SW4 | 706.104 |
| Spur - Araseurs | | 14x14x2 | 750.111 |
| Torx screw - Vis Torx | | M5x6 | 705.425 |
| Torx wrench - Clé Torx | | SW4 | 706.304 |
| Adjusting gauge - Calibre de réglage | | 0,3/0,8 | 717.309 |

MAN HW

536

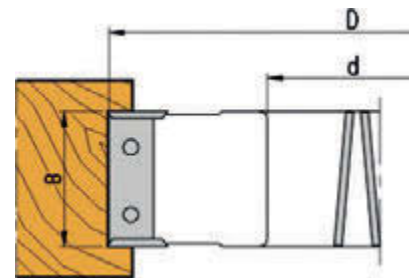

2

Rebating cutterblock Fraise pour feuillure droite

| D | B | d | Z | V | n min.-max. | Ref. |
|-----|----|-------|---|---|----------------|---------|
| 140 | 30 | 30/50 | 4 | 4 | 5500-9500 | 015.302 |
| | 50 | 30/50 | 4 | 4 | 5500-9500 | 015.304 |

MAN HW

015

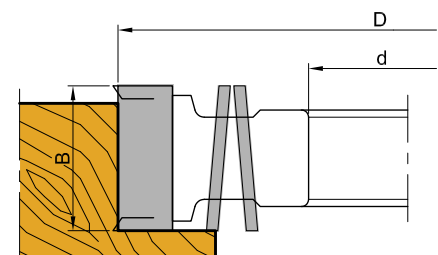

Joining diamond cutter
Fraise à calibrer, DP



MEC DP

A809

| D | B/e | d | DKN | Z | | Ref.LH | Ref.RH |
|--------------------|---------|---------|---------|---------|-----|-----------------|-----------------|
| Biesse | | | | | | | |
| 80 | 48/25 | 20 | 6,5x3,5 | 2 | B+2 | A809.080.048.20 | A809.080.148.20 |
| | 65/53 | 30 | 8x3 | 3+3 | A+2 | A809.080.265.30 | A809.080.265.30 |
| 125 | 42/47 | 30 | 8x3 | 3+3 | A+1 | A809.125.142.30 | A809.125.142.30 |
| | 63/47 | 30 | 8x3 | 3+3 | A+2 | A809.125.363.30 | A809.125.363.30 |
| Bi-Matic | | | | | | | |
| new | 60 | 52/28 | 16 | | 3+3 | A+2 | A809.060.054.16 |
| Cehisa | | | | | | | |
| 100 | 50/25 | 20 | 6x3 | 2 | B+2 | A809.100.050.20 | A809.100.150.20 |
| Griggio | | | | | | | |
| new | 80 | 65/25 | 20 | 6,5x3,5 | 2+2 | B+2 | A809.080.365.20 |
| SCM-Stefani | | | | | | | |
| 80 | 65/67 | 30 | 8x3 | 3+3 | B+1 | A809.080.065.30 | A809.080.165.30 |
| new | 100 | 64/40,6 | 30 | 8x3 | 3+3 | B+3 | A809.100.264.30 |
| IMA/Brandt | | | | | | | |
| 100 | 34/36 | 30 | 8x3 | 3+3 | B+1 | A809.100.034.30 | A809.100.134.30 |
| | 45/40,6 | 30 | 8x3 | 3+3 | B+3 | A809.100.043.30 | A809.100.143.30 |
| IMA | | | | | | | |
| 125 | 34/34 | 30 | 8x3 | 3+3 | B+1 | A809.125.034.30 | A809.125.134.30 |
| | 43/42 | 30 | 8x3 | 3+3 | B+1 | A809.125.043.30 | A809.125.143.30 |
| | 63/42 | 30 | 8x3 | 3+3 | B+3 | A809.125.063.30 | A809.125.163.30 |
| HolzHer | | | | | | | |
| new | 70 | 54/31 | 30 | 8x3 | 2+2 | B+2 | A809.070.054.30 |
| new | | 64/39 | 30 | 8x3 | 2+2 | B+2 | A809.070.064.30 |
| | 100 | 48/25 | 30 | 8x3 | 2+2 | B+2 | A809.100.048.30 |
| new | | 63/25 | 30 | 8x3 | 3+3 | B+2 | A809.100.063.30 |
| Homag | | | | | | | |
| 125 | 34/36 | 30 | 8x3 | 3+3 | A+1 | A809.125.234.30 | A809.125.234.30 |
| | 63/40 | 30 | 8x3 | 3+3 | A+2 | A809.125.263.30 | A809.125.263.30 |
| 180 | 43/58,5 | 35 | 10x3,3 | 4+4 | B+1 | A809.180.043.35 | A809.180.143.35 |
| | 63/58,5 | 35 | 10x3,3 | 4+4 | B+1 | A809.180.063.35 | A809.180.163.35 |
| Ott | | | | | | | |
| new | 85 | 60/50 | 30 | 8x3 | 3+3 | B+3 | A809.085.060.30 |
| new | | 45/47 | 30 | 8x3 | 3+3 | B+1 | A809.085.045.30 |

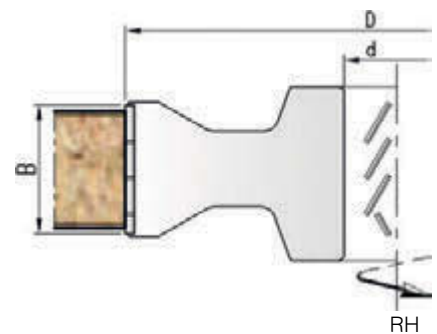
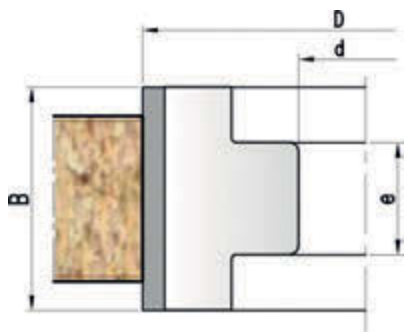

| D | B | d | Z | | Ref. | |
|------------|-----|-------|----|---------|------|-----------------|
| new | 100 | 34/36 | 50 | 8x3 3+3 | B+1 | A809.100.134.50 |
| new | 125 | 34/34 | 50 | 8x3 3+3 | B+1 | A809.125.134.50 |

Cutters arrangement.
Emplacement des dents.



Body design.
Forme du corps.

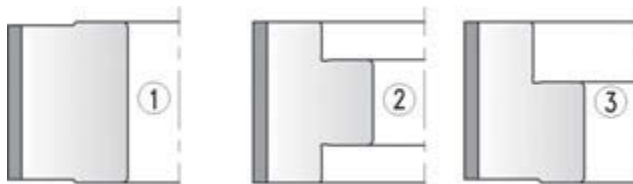

Jointing diamond cutter
Fraise à calibrer, DP

| | D | B | d | DKN | Z | Ref. |
|--------|-----|----|----|-----|-----|-----------------|
| DP=5mm | | | | | | |
| new | 100 | 25 | 30 | 8x3 | 3+3 | A827.100.125.30 |
| new | | 35 | 30 | 8x3 | 3+3 | A827.100.135.30 |
| new | | 48 | 30 | 8x3 | 3+3 | A827.100.148.30 |
| new | 125 | 35 | 30 | 8x3 | 3+3 | A827.125.135.30 |
| new | | 48 | 30 | 8x3 | 3+3 | A827.125.148.30 |

MEC DP

A827



Big feed speeds, up to 45 mt/min, as well as big cut depths.
Excellent finishing both on the bottom and top edges of the material.

Vitesse de coupe jusqu'à 45m/min.
Une Excellente finition du bord supérieur et inférieur.
Grandes profondeurs de coupe.

Adjustable jointing diamond cutter
Fraise à dresser extensible, DP



| | D | B | d | DKN | Z | n max. | Ref. |
|--------|-----|-------|----|------|-----|--------|-----------------|
| DP=5mm | | | | | | | |
| | 180 | 18-30 | 35 | 10x4 | 4+4 | 9000 | A807.180.130.35 |
| | | 18-30 | 35 | 10x4 | 6+6 | 9000 | A807.180.230.35 |
| | 200 | 18-30 | 35 | 10x4 | 4+4 | 8000 | A807.200.130.35 |
| | | 18-30 | 35 | 10x4 | 6+6 | 8000 | A807.200.230.35 |

MEC DP

A807

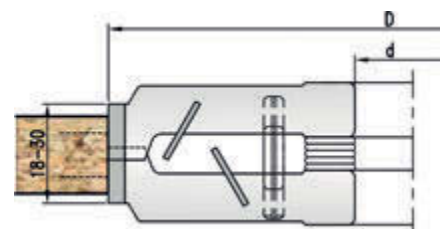
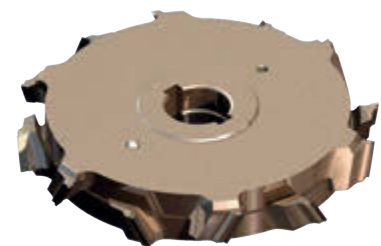

Jointing cutterhead Porte-outils à calibrer

| D | B | d | Z | n min.-max. | Ref. |
|-----|----|-----------|-----|----------------|---------|
| 100 | 56 | 30 DKN | 3+3 | 7800-13300 | 535.100 |
| 125 | 56 | 30/40 DKN | 3+3 | 6200-10600 | 535.102 |
| 150 | 56 | 30/40 DKN | 3+3 | 5200-8900 | 535.303 |
| 180 | 56 | 30/40 DKN | 3+3 | 4300-7400 | 535.512 |

Spare parts - Pièces de rechange

| | B | Dim. | Ref. |
|---------------------------------------------|----|-----------|--------------------------------|
| Knife - <i>Plaque</i> | 30 | 30x12x1,5 | 752.102 |
| Clamping wedge - <i>Cale</i> | | | RH 707.133.30 LH 707.130.30 |
| Screw - <i>Vis</i> | | M8x16 | 705.542 |
| T Wrench - <i>Clé en T</i> | | SW4 | 706.104 |
| Adjusting gauge - <i>Calibre de réglage</i> | | 1,0 | 717.302 |

MAN HW

535



Cutterhead for guide Porte-outils pour guide

| Nr. | D | B | d | Z | V | n max. | Ref. |
|-----|-----|----|----|---|---|-----------|---------|
| 1 | 145 | 12 | 40 | 3 | 3 | 11000 | 527.101 |
| 2 | 145 | 12 | 40 | 2 | 2 | 11000 | 527.102 |

Spare parts - Pièces de rechange

| | B | Dim. | Ref. |
|---------------------------------------------|----|-----------|------------|
| Knife - <i>Plaque</i> | 12 | 12x12x1,5 | 754.102 |
| Clamping wedge - <i>Cale</i> | | | 707.002.10 |
| Screw - <i>Vis</i> | | M8x16 | 705.542 |
| T Wrench - <i>Clé en T</i> | | SW4 | 706.104 |
| Spur - <i>Araseurs</i> | | 14x14x2 | 750.111 |
| Torx screw - <i>Vis Torx</i> | | M5x6 | 705.425 |
| Torx wrench - <i>Clé Torx</i> | | SW4 | 706.304 |
| Adjusting gauge - <i>Calibre de réglage</i> | | 0,3/0,8 | 717.309 |

MEC HW

527

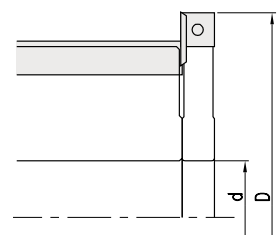
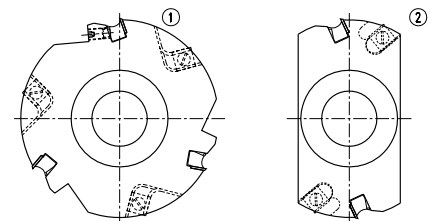

To be used in conjunction with Ref^o 506, 539 and 542.
Pour travailler en combinaison avec Ref^o 506, 539 et 542.

Planing cutterhead Porte-outils à raboter

| D | B | d | Z | n max. | Ref. | Ref. |
|-----|-----|----|---|-----------|-----------|---------|
| 125 | 80 | 40 | 4 | 9000 | 506.103 ■ | 506.203 |
| | 100 | 40 | 4 | 9000 | 506.104 ■ | 506.204 |
| | 120 | 40 | 4 | 9000 | 506.110 ■ | 506.210 |
| | 130 | 40 | 4 | 9000 | 506.105 ■ | 506.205 |
| | 150 | 40 | 4 | 9000 | 506.106 ■ | 506.206 |
| | 180 | 40 | 4 | 9000 | 506.107 ■ | 506.207 |
| | 220 | 40 | 4 | 9000 | 506.111 ■ | 506.211 |
| | 230 | 40 | 4 | 9000 | 506.108 ■ | 506.208 |
| | 240 | 40 | 4 | 9000 | 506.109 ■ | 506.209 |

■ Light alloy body - Corps en alliage léger

Spare parts - Pièces de rechange

| | B | Dim. | Ref. |
|-----------------------|-----|--------|---------|
| Clamping wedge - Cale | 80 | | 707.432 |
| | 100 | | 707.433 |
| | 120 | | 707.434 |
| | 130 | | 707.435 |
| | 150 | | 707.436 |
| | 180 | | 707.437 |
| | 220 | | 707.438 |
| | 230 | | 707.439 |
| Spring - Ressort | | | 709.122 |
| Screw - Vis | | M10x25 | 705.553 |
| T Wrench - Clé en T | | SW5 | 706.105 |

Knife - Plaquette

| | Dim. | Ref.HS (18%) | Ref.HW |
|--|----------|--------------|------------|
| | 80x30x3 | 771.080.30 | 773.080.30 |
| | 100x30x3 | 771.100.30 | 773.100.30 |
| | 120x30x3 | 771.120.30 | 773.120.30 |
| | 130x30x3 | 771.130.30 | 773.130.30 |
| | 150x30x3 | 771.150.30 | 773.150.30 |
| | 170x30x3 | 771.170.30 | 773.170.30 |
| | 180x30x3 | 771.180.30 | 773.180.30 |
| | 200x30x3 | 771.200.30 | 773.200.30 |
| | 220x30x3 | 771.220.30 | 773.220.30 |
| | 230x30x3 | 771.230.30 | 773.230.30 |
| | 240x30x3 | 771.240.30 | 773.240.30 |

MEC HS

506



2

Tipped with HS 18% knives.
HW knives under request.

Avec couteaux HS 18%.
Couteaux HW sur demande.

Cutting material recommendation Matériel de coupe recommandée

| | |
|-------------------------------|----|
| Softwood Pour bois tendres | HS |
| Hardwood Bois dur | HW |

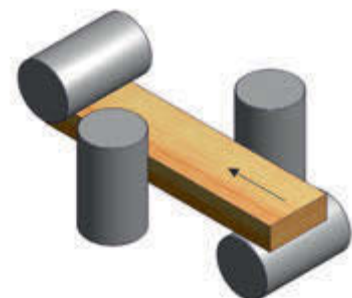
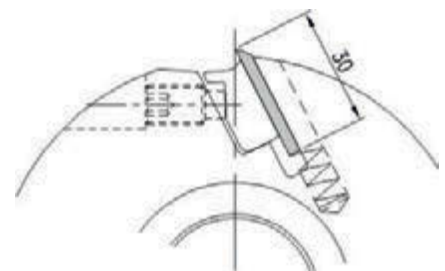

Hydro planing cutterhead Porte-outils hydro à raboter

MEC HS

563



Hydro-planerhead for finish planing of solid woods on profile moulder machines.
Supplied with HS 18% knives, not assembled.

Porte-outils Hydro pour raboter du bois naturel sur moulurières.
Livré avec couteaux HS 18%, non montés.

Pressure nipple scheme:

Schéma pour la distribution de pression:

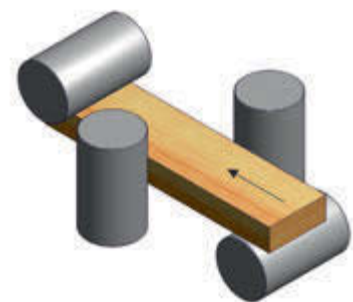
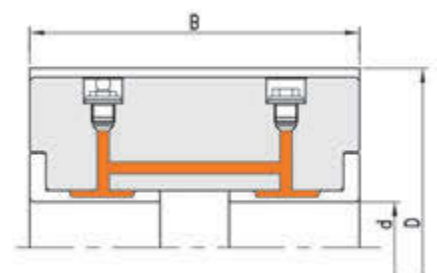
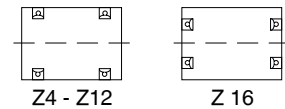

| D | B | d | Z | n max. | Ref. | |
|-----|-----|-----|----|-----------|---------|---------|
| 143 | 60 | 40 | 4 | 9000 | 563.100 | |
| | 100 | 40 | 4 | 9000 | 563.102 | |
| | 130 | 40 | 4 | 9000 | 563.103 | |
| | 150 | 40 | 4 | 9000 | 563.104 | |
| | 180 | 40 | 4 | 9000 | 563.105 | |
| | 230 | 40 | 4 | 9000 | 563.106 | |
| 143 | 60 | 40 | 6 | 9000 | 563.150 | |
| | 100 | 40 | 6 | 9000 | 563.152 | |
| | 130 | 40 | 6 | 9000 | 563.153 | |
| | 150 | 40 | 6 | 9000 | 563.154 | |
| | 180 | 40 | 6 | 9000 | 563.155 | |
| | 230 | 40 | 6 | 9000 | 563.156 | |
| 163 | 60 | 50 | 4 | 8000 | 563.201 | |
| | 100 | 50 | 4 | 8000 | 563.203 | |
| | 130 | 50 | 4 | 8000 | 563.204 | |
| | 150 | 50 | 4 | 8000 | 563.205 | |
| | 180 | 50 | 4 | 8000 | 563.206 | |
| | 230 | 50 | 4 | 8000 | 563.207 | |
| 163 | 60 | 50 | 6 | 8000 | 563.301 | |
| | 100 | 50 | 6 | 8000 | 563.303 | |
| | 130 | 50 | 6 | 8000 | 563.304 | |
| | 150 | 50 | 6 | 8000 | 563.305 | |
| | 180 | 50 | 6 | 8000 | 563.306 | |
| | 230 | 50 | 6 | 8000 | 563.307 | |
| 163 | 60 | 50 | 8 | 8000 | 563.401 | |
| | 100 | 50 | 8 | 8000 | 563.403 | |
| | 130 | 50 | 8 | 8000 | 563.404 | |
| | 150 | 50 | 8 | 8000 | 563.405 | |
| | 180 | 50 | 8 | 8000 | 563.406 | |
| | 230 | 50 | 8 | 8000 | 563.407 | |
| new | 203 | 60 | 50 | 12 | 6000 | 563.410 |
| new | | 80 | 50 | 12 | 6000 | 563.411 |
| new | | 100 | 50 | 12 | 6000 | 563.412 |
| new | | 130 | 50 | 12 | 6000 | 563.413 |
| new | | 150 | 50 | 12 | 6000 | 563.414 |
| new | | 180 | 50 | 12 | 6000 | 563.415 |
| new | | 230 | 50 | 12 | 6000 | 563.416 |
| new | 203 | 60 | 50 | 16 | 6000 | 563.420 |
| new | | 80 | 50 | 16 | 6000 | 563.421 |
| new | | 100 | 50 | 16 | 6000 | 563.422 |
| new | | 130 | 50 | 16 | 6000 | 563.423 |
| new | | 150 | 50 | 16 | 6000 | 563.424 |
| new | | 180 | 50 | 16 | 6000 | 563.425 |
| new | | 230 | 50 | 16 | 6000 | 563.426 |

Spare parts on next page - Pièces de rechange à la page suivante

Spare parts - Pièces de rechange

| | B | Dim. | Ref. |
|-----------------------------------|-----|--------|------------|
| Clamping wedge - Cale | 60 | | 707.431 |
| | 100 | | 707.433 |
| | 130 | | 707.435 |
| | 150 | | 707.436 |
| | 180 | | 707.437 |
| Screw - Vis | 230 | | 707.439 |
| | | M10x20 | 705.552.01 |
| T Wrench- Clé en T | | SW5 | 706.105 |
| Grease pump - Pompe de chargement | | | 724.401 |
| Grease cartridge - Charge | | | 724.402 |
| Safety ring - Bague de sécurité | | | 724.404 |

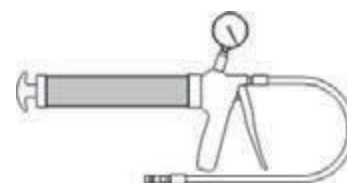
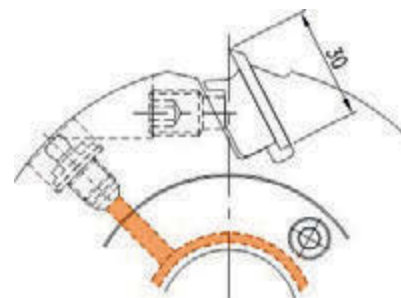

You should always use the safety ring (1) while setting up the cutter. See chapter 10.

Utiliser toujours la bague de sécurité (1) pour montage du porte-outils hydro. Voir le chapitre 10.

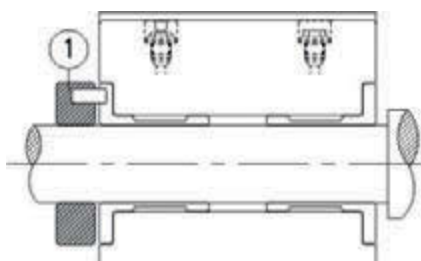

Knife - Plaquette

| | Dim. | Ref.HS (18%) | Ref.HW |
|--|----------|--------------|------------|
| | 80x30x3 | 771.080.30 | 773.080.30 |
| | 100x30x3 | 771.100.30 | 773.100.30 |
| | 120x30x3 | 771.120.30 | 773.120.30 |
| | 130x30x3 | 771.130.30 | 773.130.30 |
| | 150x30x3 | 771.150.30 | 773.150.30 |
| | 170x30x3 | 771.170.30 | 773.170.30 |
| | 180x30x3 | 771.180.30 | 773.180.30 |
| | 200x30x3 | 771.200.30 | 773.200.30 |
| | 220x30x3 | 771.220.30 | 773.220.30 |
| | 230x30x3 | 771.230.30 | 773.230.30 |
| | 240x30x3 | 771.240.30 | 773.240.30 |

Recommended cutting material

Matériel de coupe recommandée

| | |
|-------------------------------|----|
| Softwood Pour bois tendres | HS |
| Hardwood Bois dur | HW |

| D | B | d | Z | n ⁿ min.-max. | Ref. |
|------------|-----|----|---|-----------------------------|---------|
| 125 | 80 | 40 | 4 | 10000 | 587.101 |
| | 100 | 40 | 4 | 10000 | 587.102 |
| | 130 | 40 | 4 | 10000 | 587.103 |
| | 150 | 40 | 4 | 10000 | 587.104 |
| | 180 | 40 | 4 | 10000 | 587.105 |
| | 230 | 40 | 4 | 10000 | 587.106 |
| new | 240 | 40 | 4 | 10000 | 587.107 |

Knife - Plaquette

| Dim. | Ref.HS | Ref.HW |
|----------|------------|------------|
| 80x16x3 | 793.080.16 | 792.080.16 |
| 100x16x3 | 793.100.16 | 792.100.16 |
| 130x16x3 | 793.130.16 | 792.130.16 |
| 150x16x3 | 793.150.16 | 792.150.16 |
| 180x16x3 | 793.180.16 | 792.180.16 |
| 230x16x3 | 793.230.16 | 792.230.16 |
| 240x16x3 | 793.240.16 | 792.240.16 |

MEC HS
HW

587



Cutterhead supplied with HS knives.

Porte-outils fourni avec couteaux HS.

Advantages:

- Easy to use, as knife change only takes a few seconds.
- No need any kind of adjustment when clamping the knives.
- Reversible knives with 2 cutting edges
- Better finish in all kinds of solid woods
- HW and HS knives, available on stock
- Maximum noise reduction

Avantages:

- Remplacement de couteaux facile et rapide
- N'a pas besoin de réglage pour le montage des couteaux.
- Couteaux réversibles avec 2 arêtes de coupe
- Meilleure finition dans l'usinage de tous les genres de bois massif.
- Couteaux HW et HS disponible en stock.
- Réduction du niveau de bruit.

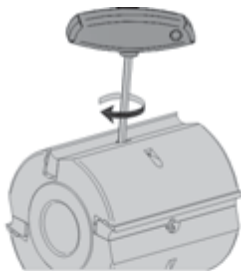

Release the pressure of the knives.
Libérez la pression des couteaux.

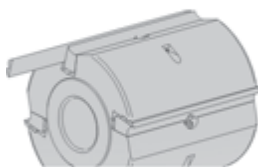

Remove/Replace the knives axially.
Enlevez/Remplacer les couteaux axialement.

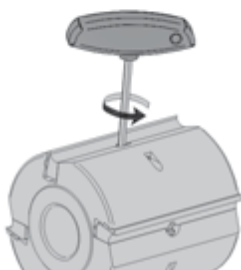

Activate the knife clamping pressure.
Activez la pression du contrefer.

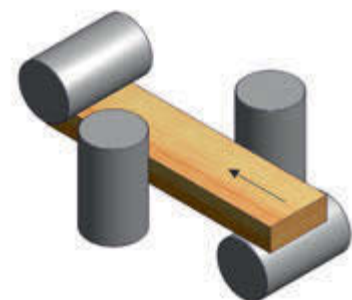

| D | B | S | Z | n min.-max. | Ref LH/INF | Ref RH/SUP | |
|-----|-----|----------|----------|----------------|------------|------------|------------|
| 93 | 60 | HSK 85WE | 2 | 12.000 | 602.201.61 | 602.211.61 | |
| | 80 | HSK 85WE | 2 | 12.000 | 602.202.61 | 602.212.61 | |
| | 100 | HSK 85WE | 2 | 12.000 | 602.203.61 | 602.213.61 | |
| | 130 | HSK 85WE | 2 | 12.000 | 602.204.61 | 602.214.61 | |
| | 150 | HSK 85WE | 2 | 12.000 | 602.205.61 | 602.215.61 | |
| | 170 | HSK 85WE | 2 | 12.000 | 602.206.61 | 602.216.61 | |
| | 190 | HSK 85WE | 2 | 12.000 | 602.207.61 | 602.217.61 | |
| | 210 | HSK 85WE | 2 | 12.000 | 602.208.61 | 602.218.61 | |
| | 240 | HSK 85WE | 2 | 12.000 | 602.209.61 | 602.219.61 | |
| new | 93 | 60 | HSK 85WE | 4 | 12.000 | 602.241.61 | 602.251.61 |
| new | | 80 | HSK 85WE | 4 | 12.000 | 602.242.61 | 602.252.61 |
| new | | 100 | HSK 85WE | 4 | 12.000 | 602.243.61 | 602.253.61 |
| new | | 130 | HSK 85WE | 4 | 12.000 | 602.244.61 | 602.254.61 |
| new | | 150 | HSK 85WE | 4 | 12.000 | 602.245.61 | 602.255.61 |
| new | | 170 | HSK 85WE | 4 | 12.000 | 602.246.61 | 602.256.61 |
| new | | 190 | HSK 85WE | 4 | 12.000 | 602.247.61 | 602.257.61 |
| new | | 210 | HSK 85WE | 4 | 12.000 | 602.248.61 | 602.258.61 |
| new | | 240 | HSK 85WE | 4 | 12.000 | 602.249.61 | 602.259.61 |

MEC HS
HW

602



For Weing Powermat moulding machines.
Cutterhead supplied with HS knives

Pour Weing Powermat machines moulurières. Porte-outils fourni avec HS.

Advantages:

- Easy to use, as knife change only takes a few seconds.
- No need any kind of adjustment when clamping the knives.
- Reversible knives with 2 cutting edges
- Better finish in all kinds of solid woods
- HW and HS knives, available on stock
- Maximum noise reduction

Avantages:

- Remplacement de couteaux facile et rapide
- N'a pas besoin de réglage pour le montage des couteaux.
- Couteaux réversibles avec 2 arêtes de coupe
- Meilleure finition dans l'usinage de tous les genres de bois massif.
- Couteaux HW et HS disponibles en stock.
- Réduction du niveau de bruit.



Knife - Plaquette

| Dim. | Ref.HS | Ref.HW |
|----------|------------|------------|
| 80x16x3 | 793.080.16 | 792.080.16 |
| 100x16x3 | 793.100.16 | 792.100.16 |
| 130x16x3 | 793.130.16 | 792.130.16 |
| 150x16x3 | 793.150.16 | 792.150.16 |
| 180x16x3 | 793.180.16 | 792.180.16 |
| 230x16x3 | 793.230.16 | 792.230.16 |
| 240x16x3 | 793.240.16 | 792.240.16 |



Release the pressure of the knives.
Libérez la pression des couteaux.



Remove/Replace the knives axially.
Enlevez/Remplacer les couteaux axialement.



Activate the knife clamping pressure.
Activez la pression du contrefer.

Production by request

Cutter body can be made in light alloy, reducing the weight of the tool and the power needs by the machine.

Production sur demande

Le corps peut être fabriqué en acier ou alliage léger. L'outil fabriqué en alliage léger, réduit le poids de l'outil et l'effort du moteur de la machine.



Pedido de consulta para arvore de aplainar
Demande de requête pour arbre de rabotage

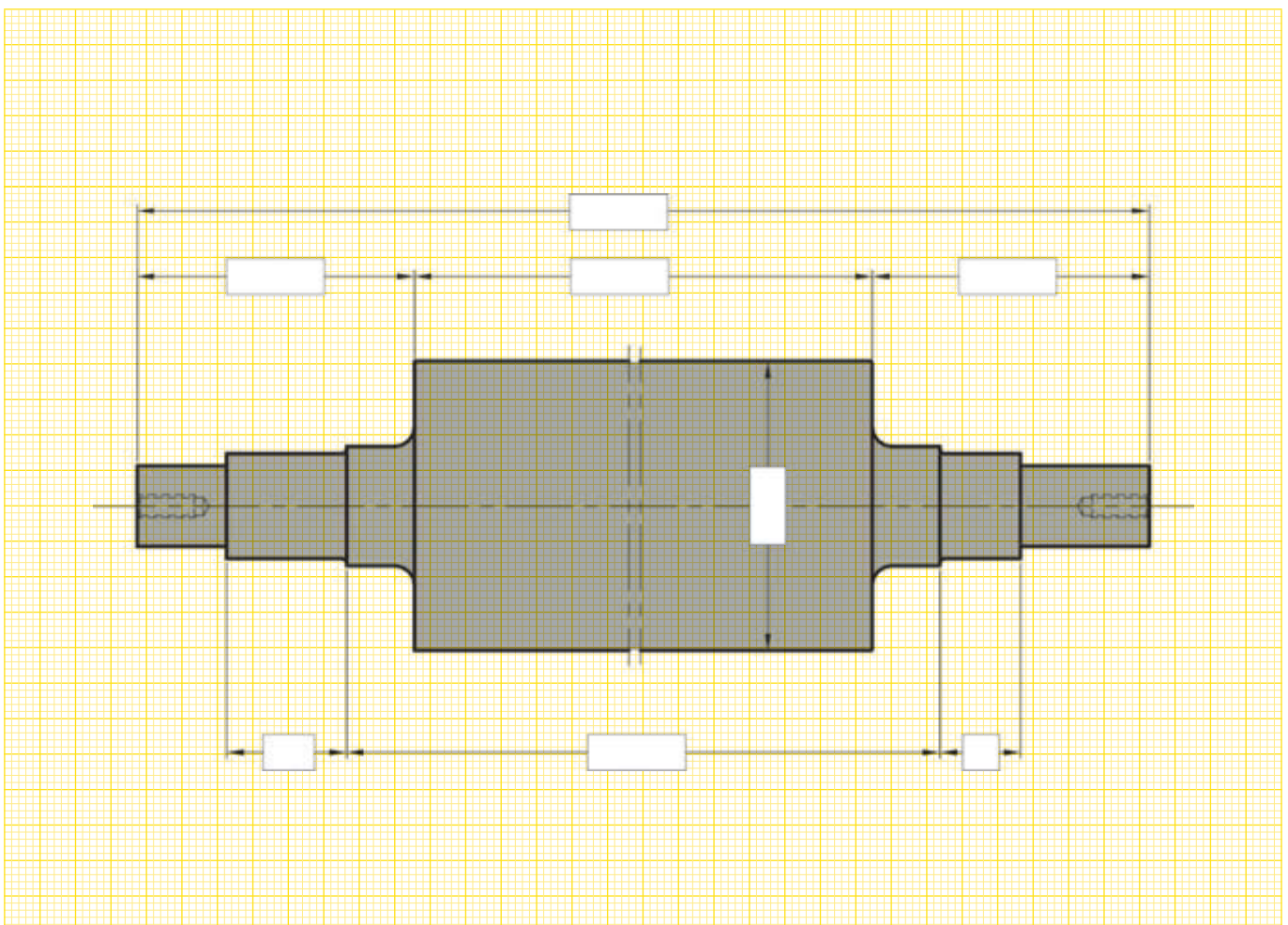

Helicoidal planing cutterhead Porte-outils hélicoïdal à raboter

| D | B | d | Z | n _{max.} | Ref. |
|-----|-------|-------|--------|-------------------|-----------|
| 100 | 119 | 50 | 3 (21) | 13300 | 542.501 |
| | 119 | 30/35 | 3 (21) | 13300 | 542.101 ■ |
| 125 | 88 | 35/40 | 3 (15) | 11000 | 542.201 ■ |
| | 119 | 35/40 | 3 (21) | 11000 | 542.203 ■ |
| | 139 | 35/40 | 3 (24) | 11000 | 542.204 ■ |
| | 156 | 35/40 | 3 (27) | 11000 | 542.205 ■ |
| | 173 | 35/40 | 3 (30) | 11000 | 542.206 ■ |
| | 218 | 35/40 | 3 (39) | 11000 | 542.209 ■ |
| | 234,5 | 35/40 | 3 (42) | 11000 | 542.210 ■ |

■ Light alloy body - Corps en alliage léger

Spare parts - Pièces de rechange

| | Dim. | Ref. |
|-----------------------|-----------|---------|
| Knife - Plaquette | 20x12x1,5 | 755.101 |
| Clamping wedge - Cale | | 707.132 |
| Screw - Vis | M8x16 | 705.542 |
| T Wrench - Clé en T | SW4 | 706.104 |

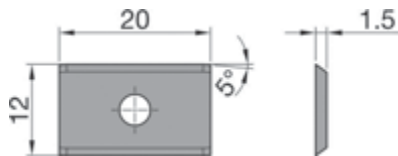

MEC HW

542

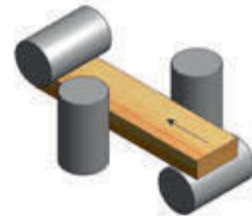

2

Planing cutterhead Porte-outils à raboter

| D | B | d | Z | n _{max.} | Ref. |
|-----|-----|----|-------|-------------------|-----------|
| 125 | 130 | 40 | 3(9) | 10200 | 574.501 ■ |
| | 230 | 40 | 3(15) | 10200 | 574.101 ■ |

■ Light alloy body - Corps en alliage léger

Spare parts - Pièces de rechange

| | Dim. | Ref. |
|--------------------------------------|-----------|------------|
| Knife - Plaquette | 50x12x1,5 | 755.105 |
| Clamping wedge - Cale | | 707.002.48 |
| Screw - Vis | M8x16 | 705.542 |
| T Wrench - Clé en T | SW4 | 706.104 |
| Adjusting gauge - Calibre de réglage | 1,0 | 717.302 |



MEC HW

574

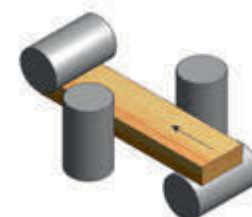

Helicoidal planing cutterhead Porte-outils hélicoïdal à raboter

| D | B | d | Z | n ⁿ min.-max. | Ref. |
|----|-----|----|--------|-----------------------------|---------|
| 80 | 100 | 50 | 3 (30) | 9500-15000 | 539.001 |

MAN HW

539

Spare parts - Pièces de rechange

| | Dim. | Ref. |
|---------------------|---------|---------|
| Knife - Plaquette | 14x14x2 | 750.111 |
| Screw - Vis | M5x7 | 705.425 |
| T Wrench - Clé en T | T15 | 706.304 |



| D | B | d | Z | n ⁿ max. | Ref. | |
|-----|-----|-----|--------|------------------------|-----------|-----------|
| 125 | 100 | 40 | 3 (30) | 10000 | 539.202 ■ | |
| | | 130 | 40 | 3 (36) | 10000 | 539.204 ■ |
| | | 180 | 40 | 3 (48) | 10000 | 539.206 ■ |
| | | 230 | 40 | 3 (60) | 10000 | 539.208 ■ |

MEC HW

■ Light alloy body - Corps en alliage léger

Spare parts - Pièces de rechange

| | Dim. | Ref. |
|---------------------|-----------|------------|
| Knife - Plaquette | 15x15x2,5 | 754.106 |
| Screw - Vis | M5x13 | 705.320.13 |
| T Wrench - Clé en T | T20 | 706.305 |



Standard



Under request.
[Sur demande.](#)

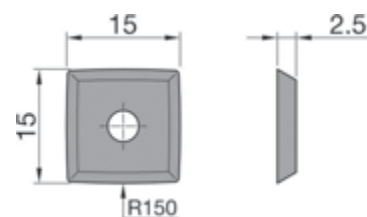

Helicoidal planing cutterblock Fraise hélicoïdale à raboter

| | D | B | d | Z | n _{max.} | Ref. |
|-----|-----|-----|----|----|-------------------|---------|
| | 125 | 120 | 40 | 12 | 12000 | 048.401 |
| | | 180 | 40 | 12 | 12000 | 048.402 |
| | | 230 | 40 | 12 | 12000 | 048.501 |
| new | 140 | 120 | 40 | 12 | 10500 | 048.101 |
| new | | 180 | 40 | 12 | 10500 | 048.102 |
| new | | 230 | 40 | 12 | 10500 | 048.301 |

MEC HW

048

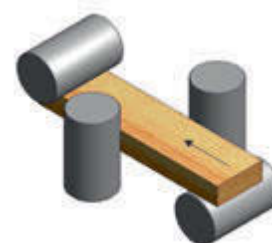

2

Helicoidal planing cutterblock Fraise hélicoïdale à raboter

| | D | B | d | Z | n _{min.-max.} | Ref. |
|-----|------|-----|----|----|------------------------|---------|
| new | 100 | 120 | 35 | 12 | 7800-13300 | 049.104 |
| new | | 180 | 35 | 12 | 7800-13300 | 049.105 |
| | Pade | | | | | |
| new | 120 | 180 | 35 | 12 | 6400-11100 | 049.201 |

MAN HW

049

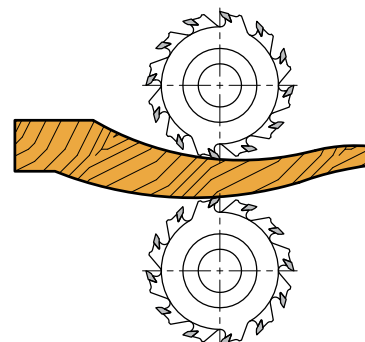

Planing cutterblock with offset teeth for big chip removal.
Specially suitable when working against the wood grain.

Fraise hélicoïdale à raboter avec dents alternées, ce qui lui confère une grande puissance d'extraction.
Cet outil est spécialement conçu pour travailler au sens inverse de la fibre.

Cutterhead for tenoning machine Porte-outils pour tenonneuse à tenons ronds

| D | D1 | B | d | Z | V | n _{max.} | Ref. |
|-----------------------------------|-----|------|----|-----|-----|-------------------|---------|
| Bacci - Balestrini - Pade - Greda | | | | | | | |
| 90 | 135 | 5-50 | 30 | 3/6 | 3/6 | 10200 | 560.101 |
| Nipuer | | | | | | | |
| 115 | 160 | 5-30 | 35 | 3/6 | 3/6 | 8500 | 560.301 |

MEC HW

560



Single tenoning machine - Tenonneuse simple

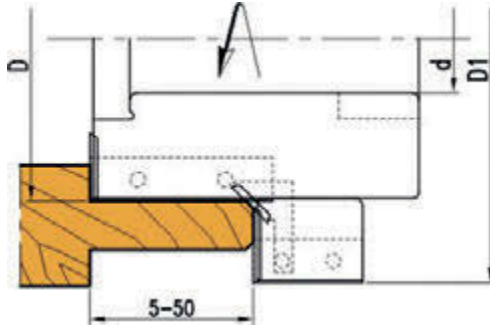

| D | D1 | B | d | Z | V | n _{max.} | Ref. |
|-----------------------------------|-----|------|----|-----|-----|-------------------|---------|
| Bacci - Balestrini - Pade - Greda | | | | | | | |
| 70 | 115 | 5-50 | 25 | 3/6 | 3/6 | 11600 | 560.201 |
| | 115 | 5-50 | 25 | 3/6 | 3/6 | 11600 | 560.202 |

Double tenoning machine - Tenonneuse double

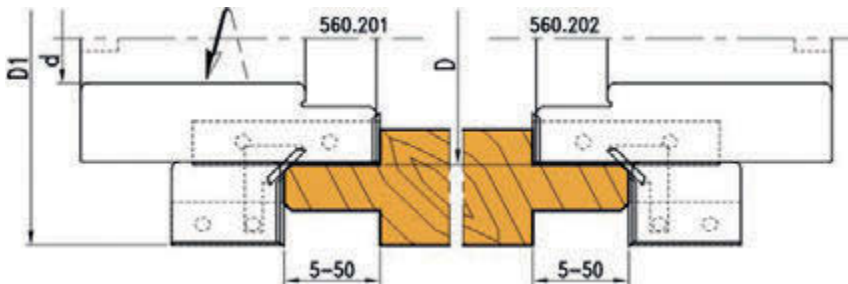

Spare parts - Pièces de rechange

| | Dim. | Ref. |
|---------------------------------------------|-----------|------------|
| Knife - <i>Plaquette</i> | 30x12x1,5 | 750.104 |
| | 50x12x1,5 | 750.106 |
| Clamping wedge - <i>Cale</i> | | 707.002.28 |
| | | 707.002.48 |
| Screw - <i>Vis</i> | M8x16 | 705.542 |
| | M8x25 | 705.543 |
| T Wrench - <i>Clé en T</i> | SW4 | 706.104 |
| Spur - <i>Araseurs</i> | 14x14x2 | 750.111 |
| Torx screw - <i>Vis Torx</i> | M5x6 | 705.425 |
| Torx wrench - <i>Clé Torx</i> | SW4 | 706.304 |
| Adjusting gauge - <i>Calibre de réglage</i> | 0,3/0,8 | 717.309 |

Cutterhead for edge banding machine Porte-outils pour plaqueuse de chants

| D | B/b | d | DKN | Z | n _{max.} | Ref. | |
|---------------------------------------|-------|-------|-------|-------|-------------------|---------|---------|
| Brandt - Homag - IDM - Stefani | | | | | | | |
| 70 | 12/10 | 16 | 5x2,3 | 4 | 18000 | 502.301 | |
| | 12/10 | 16 | 5x2,3 | 6 | 18000 | 502.302 | |
| Holz-Her | | | | | | | |
| 80 | 40/25 | 30 | 8x3,3 | 4 | 18000 | 502.502 | |
| Holz-Her - Homag - IMA | | | | | | | |
| 70 | 20/10 | 20 | 6x3,5 | 4 | 18000 | 502.309 | |
| Homag - Homburg | | | | | | | |
| 50 | 12/10 | 16 | 5x2,3 | 2 | 18000 | 502.101 | |
| IMA - Raimann | | | | | | | |
| 50 | 15/10 | 16 | 5x2,3 | 2 | 18000 | 502.102 | |
| Olimpic | | | | | | | |
| 70 | 30/12 | 16 | 6x3,5 | 4 | 18000 | 502.311 | |
| Ott | | | | | | | |
| 70 | 20/10 | 16 | 5x2,3 | 4 | 18000 | 502.305 | |
| SCM-Stefani | | | | | | | |
| 70 | 20/11 | 16 | 6x3,5 | 6 | 18000 | 502.307 | |
| new | 15/10 | 16 | 6x3,5 | 4 | 18000 | 502.313 | |
| new | 72 | 20/11 | 16 | 6x3,5 | 4 | 18000 | 502.314 |
| new | 75 | 20/11 | 16 | 6x3,5 | 4 | 18000 | 502.401 |
| new | 30/11 | 16 | 6x3,5 | 4 | 18000 | 502.402 | |
| | 80 | 20/11 | 16 | 5x2,3 | 4 | 18000 | 502.503 |
| | | 30/11 | 16 | 5x2,3 | 4 | 18000 | 502.504 |

Spare parts - Pièces de rechange

| | B | Dim. | Ref. |
|---------------------------------------------|----|-----------|------------|
| Knife - Plaque | | 12x12x1,5 | 754.102 |
| | | 15x12x1,5 | 750.101 |
| | | 20x12x1,5 | 750.102 |
| | | 30x12x1,5 | 750.104 |
| | | 40x12x1,5 | 750.105 |
| Clamping wedge - Cale | 12 | | 707.001.10 |
| | 15 | | 707.001.13 |
| | 20 | | 707.001.18 |
| | 30 | | 707.001.28 |
| | 40 | | 707.001.38 |
| Screw - Vis | | M6x12 | 705.533 |
| T Wrench - Clé en T | | SW3 | 706.103 |
| Adjusting gauge - Calibre de réglage | | 1,0 | 717.302 |

MEC HW

502

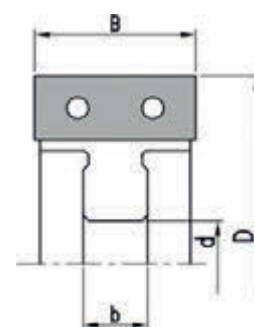

Cutterhead for edge banding machine
Porte-outils pour plaqueuse de chants

MEC HW

503



| D | B/b | d | DKN | Z | n _{max.} | Ref.LH | Ref.RH |
|---------------------------------------------------|---------|----|-------|---|-------------------|---------|---------|
| Brandt - Homag - IMA - IDM - SCM - Stefani | | | | | | | |
| 70 | 20/12,5 | 20 | 6x3,5 | 4 | 18000 | 503.302 | 503.301 |
| | 20/12,5 | 20 | 6x3,5 | 6 | 18000 | 503.304 | 503.303 |
| SCM-Stefani | | | | | | | |
| new 72 | 30/12 | 16 | 6x3,5 | 4 | 18000 | 503.314 | 503.315 |
| FRAVOL | | | | | | | |
| new 70 | 20/11,5 | 20 | 6x3,5 | 6 | 18000 | 503.310 | 503.311 |
| new 80 | 30/25,5 | 20 | 6x3,5 | 6 | 18000 | 503.312 | 503.313 |

Spare parts - Pièces de rechange

| | B | Dim. | Ref. |
|---------------------------------------------|----|-----------|------------|
| Knife - Plaque | | 20x12x1,5 | 750.102 |
| | | 30x12x1,5 | 750.104 |
| Clamping wedge - Cale | 20 | | 707.001.18 |
| | 30 | | 707.001.28 |
| Screw - Vis | | M6x12 | 705.533 |
| T Wrench - Clé en T | | SW3 | 706.103 |
| Adjusting gauge - Calibre de réglage | | 1,0 | 717.302 |



| D | B/b | d | DKN | Z | n _{max.} | Ref.LH | Ref.RH |
|----------------|---------|----|-------|---|-------------------|---------|---------|
| SCM - 1 | | | | | | | |
| 48 | 14,6/20 | 16 | 5x2,3 | 2 | 18000 | 503.401 | 503.400 |
| SCM - 2 | | | | | | | |
| 52,8 | 14,6/20 | 16 | 5x2,3 | 2 | 18000 | 503.411 | 503.410 |

Spare parts - Pièces de rechange

| | Dim. | Ref. |
|----------------------------|------------|---------|
| Knife - Plaque | 14,6x9x1,5 | 750.090 |
| Screw - Vis | M3,5x7,5 | 705.350 |
| T Wrench - Clé en T | T15 | 706.302 |

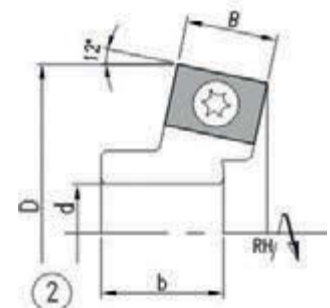
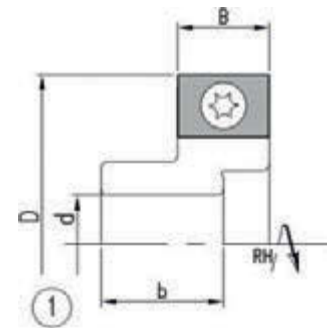

Cutterhead for edge banding machine
Porte-outils pour plaqueuse de chants

| D | B/b | d | DKN | Z | n _{max.} | Ref.LH | Ref.RH |
|---------------|-------|----|-------|---|-------------------|---------|---------|
| Biesse | | | | | | | |
| 70 | 20/22 | 20 | 6x2,8 | 6 | 18000 | 503.520 | 503.510 |
| 80 | 20/22 | 20 | 6x2,8 | 6 | 18000 | 503.521 | 503.511 |
| | 30/22 | 20 | 6x2,8 | 6 | 18000 | 503.522 | 503.512 |

Spare parts - Pièces de rechange

| | B | Dim. | Ref. |
|---------------------------------------------|----|-----------|------------|
| Knife - Plaque | | 20x12x1,5 | 750.102 |
| | | 30x12x1,5 | 750.104 |
| Clamping wedge - Cale | 20 | | 707.001.18 |
| | 30 | | 707.001.28 |
| Screw - Vis | | M6x12 | 705.533 |
| T Wrench - Clé en T | | SW3 | 706.103 |
| Adjusting gauge - Calibre de réglage | | 1,0 | 717.302 |

| D | B/b | d | DKN | Z | n _{max.} | Ref.LH | Ref.RH |
|---------------|-------|----|-------|---|-------------------|---------|---------|
| Biesse | | | | | | | |
| 70 | 16/19 | 16 | 5x2,3 | 6 | 18000 | 503.523 | 503.513 |

Spare parts - Pièces de rechange

| | B | Dim. | Ref. |
|------------------------------|----|-----------|------------|
| Knife - Plaque | | 16x17,5x2 | 765.113 |
| Clamping wedge - Cale | 16 | | 707.503.01 |
| Screw - Vis | | M6x12 | 705.533 |
| T Wrench - Clé en T | | SW3 | 706.103 |

MEC HW

503

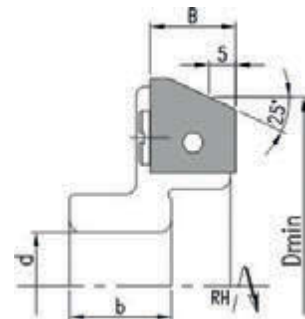

Cutterhead for edge banding machine
Porte-outils pour plaqueuse de chants

| D | B/b | d | Z | n _{max.} | Ref.LH | Ref.RH |
|-------------|---------|---------|---|-------------------|---------|---------|
| Homag - IMA | | | | | | |
| 70 | 14,3/23 | HSK 25R | 4 | 18000 | 599.102 | 599.101 |

Spare parts - Pièces de rechange

| | Dim. | Ref. |
|------------------------|---------------|------------|
| Knife - Plaquette | 14,3x14,3x2,5 | 750.116 |
| Screw - Vis | M5x13 | 705.320.13 |
| Torx wrench - Clé Torx | T20 | 706.305 |
| Screw - Vis | M10x1,25 | 705.099 |
| T Wrench - Clé en T | SW10 | 706.107 |

MEC HW

599

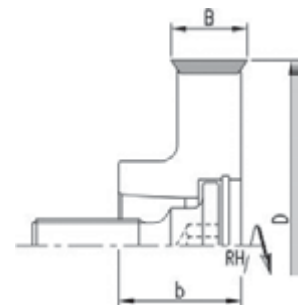

Cutterhead for edge banding machine
Porte-outils pour plaqueuse de chants

| D | B/b | d | Z | n _{max.} | Ref.LH | Ref.RH |
|-------------|-----|---------|---|-------------------|---------|---------|
| Homag - IMA | | | | | | |
| 70 | 24 | HSK 25R | 4 | 18000 | 598.102 | 598.101 |

Spare parts - Pièces de rechange

| | Dim. | Ref. |
|--------------------------------------|-------------|------------|
| Knife - Plaquette | 24,7x12x1,5 | 750.103 |
| Clamping wedge - Cale | | 707.900.24 |
| Screw - Vis | M8x12 | 705.541 |
| T Wrench - Clé en T | SW4 | 706.104 |
| Screw - Vis | M10x1,25 | 705.099 |
| Adjusting gauge - Calibre de réglage | 1,0 | 717.302 |

MEC HW

598

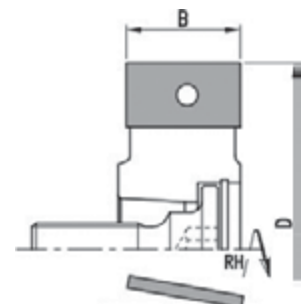

Edge banding diamond cutter
Fraise à dresser d'affleurage, DP



| D | B/b | d | Z | n _{max.} | Ref.LH | Ref.RH |
|--------------------|-------|---------|---|-------------------|-----------------|-----------------|
| Homag - IMA | | | | | | |
| 70 | 8/23 | HSK 25R | 4 | 12000 | A860.070.008.97 | A860.070.108.97 |
| | 8/23 | HSK 25R | 6 | 12000 | A860.070.308.97 | A860.070.208.97 |
| | 15/23 | HSK 25R | 4 | 12000 | A860.070.015.97 | A860.070.115.97 |
| | 15/23 | HSK 25R | 6 | 12000 | A860.070.315.97 | A860.070.215.97 |

Spare parts - Pièces de rechange

| | Dim. | Ref. |
|---------------------|----------|---------|
| Screw - Vis | M10x1,25 | 705.099 |
| T Wrench - Clé en T | SW10 | 706.107 |

MEC DP

A860

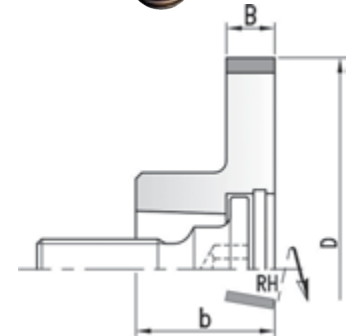

Cutterhead for edge banding machines
Porte-outils pour plaqueuse de chants

| D | D1 | B/b | d | DNK | R | Z | n _{max.} | Ref. |
|-------------------------------|------|-------|----|-------|---|---|-------------------|---------|
| Homag - Gabbiani - Ott | | | | | | | | |
| 73 | 61 | 16/11 | 16 | 5x2,3 | 2 | 3 | 18000 | 556.102 |
| | 61 | 16/11 | 16 | 5x2,3 | 3 | 3 | 18000 | 556.103 |
| | 61 | 16/11 | 16 | 5x2,3 | 4 | 3 | 18000 | 556.104 |
| | 61 | 16/11 | 16 | 5x2,3 | 5 | 3 | 18000 | 556.105 |
| HolzHer | | | | | | | | |
| 73 | 61 | 16/11 | 20 | 6x3,5 | 2 | 3 | 18000 | 556.202 |
| | 61 | 16/11 | 20 | 6x3,5 | 3 | 3 | 18000 | 556.203 |
| | 61 | 16/11 | 20 | 6x3,5 | 4 | 3 | 18000 | 556.204 |
| | 61 | 16/11 | 20 | 6x3,5 | 5 | 3 | 18000 | 556.205 |
| IDM | | | | | | | | |
| 73,3 | 61,3 | 16/10 | 16 | 5x2,3 | 2 | 3 | 18000 | 556.306 |
| | 61,3 | 16/10 | 16 | 5x2,3 | 3 | 3 | 18000 | 556.307 |
| | 61,3 | 16/10 | 16 | 5x2,3 | 4 | 3 | 18000 | 556.308 |
| | 61,3 | 16/10 | 16 | 5x2,3 | 5 | 3 | 18000 | 556.309 |
| IMA - Wilmsmeyer | | | | | | | | |
| 82 | 70 | 16/11 | 20 | 6x3,5 | 2 | 4 | 18000 | 556.302 |
| | 70 | 16/11 | 20 | 6x3,5 | 3 | 4 | 18000 | 556.303 |
| | 70 | 16/11 | 20 | 6x3,5 | 4 | 4 | 18000 | 556.304 |
| | 70 | 16/11 | 20 | 6x3,5 | 5 | 4 | 18000 | 556.305 |

Spare parts - Pièces de rechange

| | Dim. | Ref. | |
|-----------------------|-------|----------|---------|
| Knife - Plaquette | R2 | 16x17,5x | 765.101 |
| | R3 | 16x17,5x | 765.102 |
| | R4 | 16x17,5x | 765.103 |
| | R5 | 16x17,5x | 765.104 |
| Clamping wedge - Cale | | 707.155 | |
| Screw - Vis | M6x12 | 705.533 | |
| T Wrench - Clé en T | SW3 | 706.103 | |

MEC HW

556

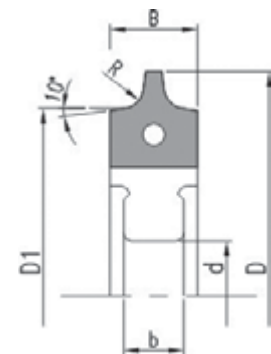

Cutterhead for edge banding machines
Porte-outils pour plaqueuse de chants

| D | D1 | B/b | d | DKN | R | Z | n _{max.} | Ref.LH | Ref.RH |
|------------|----|-------|----|-------|---|---|-------------------|---------|---------|
| IMA | | | | | | | | | |
| 82 | 70 | 16/13 | 20 | 6x3,5 | 2 | 4 | 18000 | 557.103 | 557.102 |
| | 70 | 16/13 | 20 | 6x3,5 | 3 | 4 | 18000 | 557.105 | 557.104 |
| | 70 | 16/13 | 20 | 6x3,5 | 4 | 4 | 18000 | 557.107 | 557.106 |
| | 70 | 16/13 | 20 | 6x3,5 | 5 | 4 | 18000 | 557.109 | 557.108 |

Spare parts - Pièces de rechange

| | Dim. | Ref. | |
|------------------------------|-------|-----------|---------|
| Knife - Plaquette | R2 | 16x17,5x2 | 765.101 |
| | R3 | 16x17,5x2 | 765.102 |
| | R4 | 16x17,5x2 | 765.103 |
| | R5 | 16x17,5x2 | 765.104 |
| Clamping wedge - Cale | | | 707.155 |
| Screw - Vis | M6x12 | | 705.533 |
| T Wrench - Clé en T | SW3 | | 706.103 |

MEC HW

557

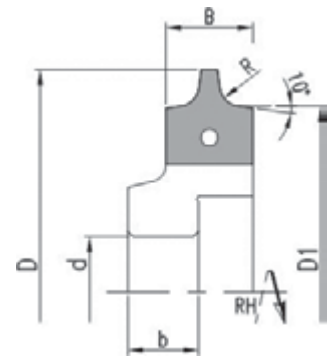

| D | D1 | B/b | d | DKN | R | Z | n _{max.} | Ref.LH | Ref.RH |
|------------|------|-------|----|-------|-----|---|-------------------|---------|---------|
| SCM | | | | | | | | | |
| 55,5 | 47,5 | 15/20 | 16 | 5x2,3 | 1 | 2 | 18000 | 557.210 | 557.200 |
| | 47,5 | 15/20 | 16 | 5x2,3 | 1,5 | 2 | 18000 | 557.211 | 557.201 |
| | 47,5 | 15/20 | 16 | 5x2,3 | 2 | 2 | 18000 | 557.212 | 557.202 |
| | 47,5 | 15/20 | 16 | 5x2,3 | 2,5 | 2 | 18000 | 557.213 | 557.203 |
| | 47,5 | 15/20 | 16 | 5x2,3 | 3 | 2 | | 557.214 | 557.204 |

Spare parts - Pièces de rechange

| | Dim. | Ref.LH | Ref.RH | |
|----------------------------|----------|-----------|---------|---------|
| Knife - Plaquette | R1 | 15x12x1,5 | 765.250 | 765.260 |
| | R1,5 | 15x12x1,5 | 765.251 | 765.261 |
| | R2 | 15x12x1,5 | 765.252 | 765.262 |
| | R2,5 | 15x12x1,5 | 765.253 | 765.263 |
| | R3 | 15x12x1,5 | 765.254 | 765.264 |
| Screw - Vis | M3,5x7,5 | | 705.350 | 705.350 |
| T Wrench - Clé en T | T15 | | 706.302 | 706.302 |

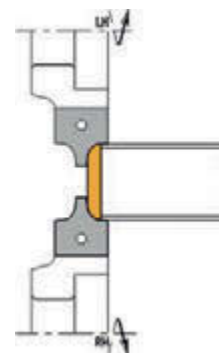
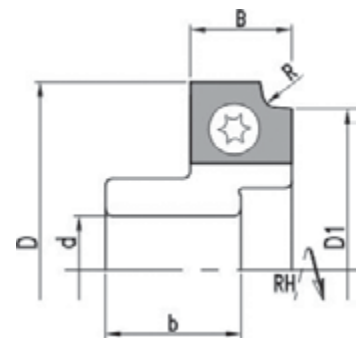

Cutterhead for edge banding machines
Porte-outils pour plaqueuse de chants

| D min. | B/b | d | DKN | R | Z | n max. | Ref.LH | Ref.RH |
|---------------|-------|----|-------|---|---|-----------|---------|---------|
| Biesse | | | | | | | | |
| 70 | 16/19 | 16 | 5x2,3 | 2 | 6 | 18000 | 557.303 | 557.302 |
| | 16/19 | 16 | 5x2,3 | 3 | 6 | 18000 | 557.305 | 557.304 |
| | 16/19 | 16 | 5x2,3 | 4 | 6 | 18000 | 557.307 | 557.306 |
| | 16/19 | 16 | 5x2,3 | 5 | 6 | 18000 | 557.309 | 557.308 |

Spare parts - Pièces de rechange

| | Dim. | Ref. | |
|------------------------------|-------|-----------|---------|
| Knife - Plaque | R2 | 16x17,5x2 | 765.101 |
| | R3 | 16x17,5x2 | 765.102 |
| | R4 | 16x17,5x2 | 765.103 |
| | R5 | 16x17,5x2 | 765.104 |
| Clamping wedge - Cale | | | 707.155 |
| Screw - Vis | M6x12 | | 705.533 |
| T Wrench - Clé en T | SW3 | | 706.103 |

| D | B | d | DKN | R | Z | n max. | Ref.LH | Ref.RH |
|---------------|----|----|-------|---------|---|-----------|---------|---------|
| Biesse | | | | | | | | |
| 75 | 25 | 20 | 6x3,5 | 1,5/2/3 | 4 | 18000 | 557.311 | 557.310 |

Spare parts - Pièces de rechange

| | Dim. | Ref.LH | Ref.RH | |
|------------------------------|------------|-----------|------------|------------|
| Knife - Plaque | R1.5/R2/R3 | 25x18,5x2 | 765.112 | 765.114 |
| Clamping wedge - Cale | | 25x18,5x2 | 707.557.01 | 707.557.02 |
| Screw - Vis | M6x12 | | 705.533 | 705.533 |
| T Wrench - Clé en T | SW3 | | 706.103 | 706.103 |

MEC HW

557

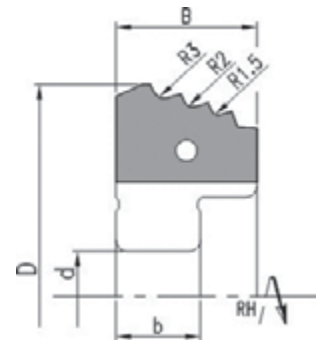
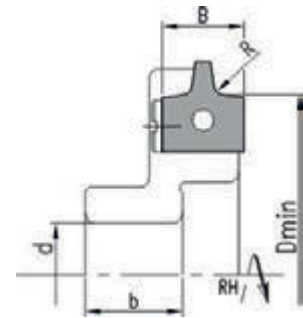

Cutterhead for edge banding machines
Porte-outils pour plaqueuse de chants

586

MEC HW

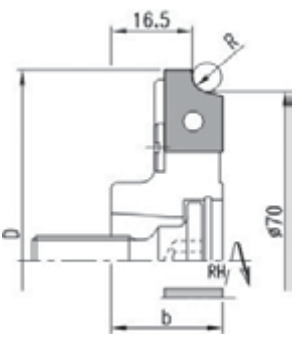
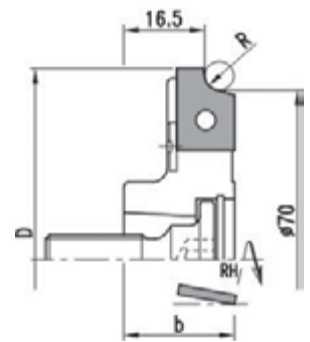

| D | b | d | Z | R | n _{max.} | Ref.LH | Ref.RH |
|--------------|----|---------|---|---|-------------------|---------|---------|
| Homag | | | | | | | |
| 79 | 23 | HSK 25R | 4 | 2 | 18000 | 586.102 | 586.101 |
| | 23 | HSK 25R | 4 | 3 | 18000 | 586.104 | 586.103 |
| 85 | 24 | HSK 25R | 4 | 4 | 17700 | 586.106 | 586.105 |
| | 24 | HSK 25R | 4 | 5 | 17700 | 586.108 | 586.107 |

Spare parts - Pièces de rechange

| | Dim. | Ref.LH | Ref.RH | |
|------------------------------|----------|------------|------------|---------|
| Knife - Plaque | R2 | 12x17x2 | 765.202 | 765.201 |
| | R3 | 12x17x2 | 765.204 | 765.203 |
| | R4 | 12x20x2 | 765.206 | 765.205 |
| | R5 | 12x20x2 | 765.208 | 765.207 |
| Clamping wedge - Cale | | 707.900.02 | 707.900.01 | |
| Screw - Vis | M6x12 | 705.533 | 705.533 | |
| T Wrench - Clé en T | SW3 | 706.103 | 706.103 | |
| Screw - Vis | M10x1,25 | 705.099 | 705.099 | |
| T Wrench - Clé en T | SW10 | 706.107 | 706.107 | |

| D | b | d | Z | R | n _{max.} | Ref.LH | Ref.RH |
|------------|----|---------|---|---|-------------------|---------|---------|
| IMA | | | | | | | |
| 79 | 23 | HSK 25R | 4 | 2 | 18000 | 586.202 | 586.201 |
| | 23 | HSK 25R | 4 | 3 | 18000 | 586.204 | 586.203 |

Spare parts - Pièces de rechange

| | Dim. | Ref.LH | Ref.RH | |
|------------------------------|----------|------------|------------|---------|
| Knife - Plaque | R2 | 12x17x2 | 765.210 | 765.209 |
| | R3 | 12x17x2 | 765.212 | 765.211 |
| Clamping wedge - Cale | | 707.902.04 | 707.902.03 | |
| Screw - Vis | M6x12 | 705.533 | 705.533 | |
| Screw - Vis | M10x1,25 | 705.099 | 705.099 | |
| T Wrench - Clé en T | SW10 | 706.107 | 706.107 | |

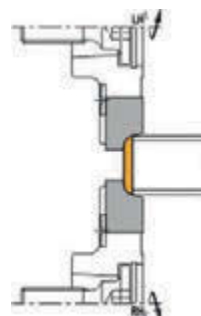

Edge rounding diamond cutter
Fraise 1/4 de rond d'affleurage



| D | R | B | d | Z | n _{max.} | Ref.LH | Ref.RH |
|--------------------|----|----|---------|---------|-------------------|-----------------|-----------------|
| Homag - IMA | | | | | | | |
| 79 | 1 | 23 | HSK 25R | 4 | 24000 | A861.079.001.97 | A861.079.101.97 |
| | 2 | 23 | HSK 25R | 4 | 24000 | A861.079.002.97 | A861.079.102.97 |
| | 2 | 23 | HSK 25R | 6 | 24000 | A861.079.302.97 | A861.079.202.97 |
| | 3 | 23 | HSK 25R | 4 | 24000 | A861.079.003.97 | A861.079.103.97 |
| | 3 | 23 | HSK 25R | 6 | 24000 | A861.079.303.97 | A861.079.203.97 |
| | 85 | 4 | 24 | HSK 25R | 4 | 24000 | A861.085.004.97 |
| 4 | | 24 | HSK 25R | 6 | 24000 | A861.085.304.97 | A861.085.204.97 |
| 5 | | 24 | HSK 25R | 4 | 24000 | A861.085.005.97 | A861.085.105.97 |
| 5 | | 24 | HSK 25R | 6 | 24000 | A861.085.305.97 | A861.085.205.97 |

MEC DP

A861

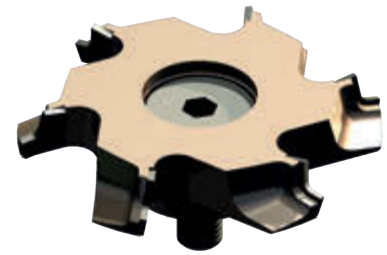

Spare parts - Pièces de rechange

| | Dim. | Ref. |
|---------------------|----------|---------|
| Screw - Vis | M10x1,25 | 705.099 |
| T Wrench - Clé en T | SW10 | 706.107 |

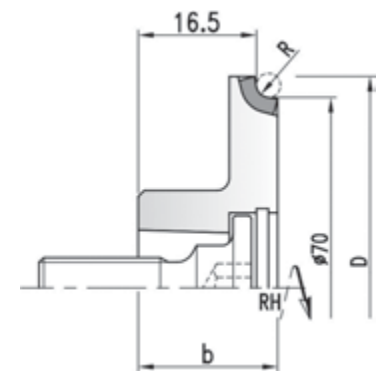
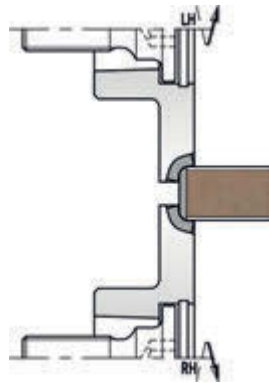

| D | R | d | Z | n _{max.} | Ref.LH | Ref.RH |
|--------------------|---|--------|---|-------------------|-----------------|-----------------|
| Homag - IMA | | | | | | |
| 75 | 1 | HSK 32 | 4 | 18000 | A861.075.001.96 | A861.075.101.96 |
| | 2 | HSK 32 | 4 | 18000 | A861.075.002.96 | A861.075.102.96 |
| | 2 | HSK 32 | 6 | 18000 | A861.075.302.96 | A861.075.202.96 |
| | 3 | HSK 32 | 4 | 18000 | A861.075.003.96 | A861.075.103.96 |
| | 3 | HSK 32 | 6 | 18000 | A861.075.303.96 | A861.075.203.96 |
| | 4 | HSK 32 | 4 | 18000 | A861.075.004.96 | A861.075.104.96 |
| | 4 | HSK 32 | 6 | 18000 | A861.075.304.96 | A861.075.204.96 |
| | 5 | HSK 32 | 4 | 18000 | A861.075.005.96 | A861.075.105.96 |
| | 5 | HSK 32 | 6 | 18000 | A861.075.305.96 | A861.075.205.96 |

Spare parts - Pièces de rechange

| | Dim. | Ref. |
|---------------------|-------|------------|
| Screw - Vis | M6x45 | 705.340.45 |
| T Wrench - Clé en T | SW3 | 706.103 |

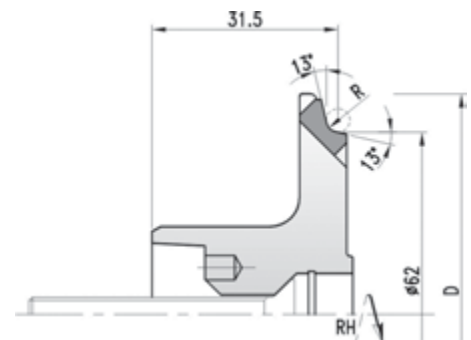

Edge rounding diamond cutter
Fraise 1/4 de rond d'affleurage, DP



| D | R | B | d | Z | n _{max.} | Ref.LH | Ref.RH |
|--------------------|-----|----|---------|---|-------------------|-----------------|-----------------|
| Homag - IMA | | | | | | | |
| 85 | 2/3 | 28 | HSK 25R | 4 | 24000 | A862.085.004.97 | A862.085.104.97 |
| | 2/3 | 28 | HSK 25R | 6 | 24000 | A862.085.006.97 | A862.085.106.97 |

MEC DP

A862

Spare parts - Pièces de rechange

| | Dim. | Ref. |
|--------------------|----------|---------|
| Screw - Vis | M10x1,25 | 705.099 |
| T Wrench- Clé en T | SW10 | 706.107 |

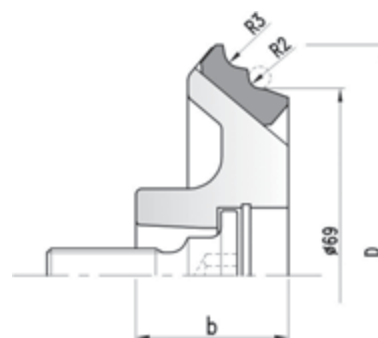
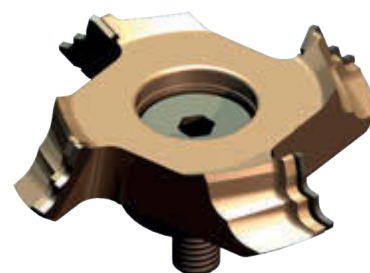

FRE

ZITE



FREZITE - Ferramentas de Corte, S.A.

Head Office / Siège social : Rua do Vau, 173, Apartado 134, 4786-909 Trofa, PORTUGAL
Tel.: +351 252 400 360 | Fax: +351 252 417 254 | e-mail: info@frezite.com

Find your local partner at / Trouvez votre partenaire de distribution à:

FREZITE Group